

KUISCID
KOÇ UNIVERSITY - İŞBANK
CENTER FOR INFECTIOUS DISEASES

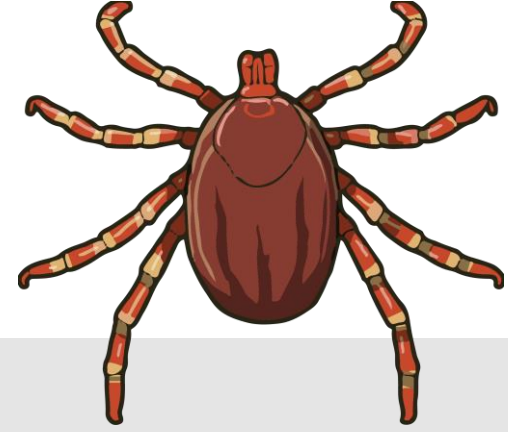

Crimean Congo Hemorrhagic Fever

Önder Ergönül, MD, MPH
Koç University School of Medicine
Infectious Diseases & Clinical Microbiology

26 October 2026



Viruses and Liver

Hepatitis viruses

Hepatitis A, B, C, D, E

Immunosuppressed patients

Herpes, Adeno, CMV, EBV

Respiratory and systemic infections

Measles, influenza, SARS-CoV, Parvo, entero, rubella

In specific geographic areas

Arenaviridae

Lassa

Bunyavirales

CCHF, Hanta, Rift Valley

Filoviridae

Ebola, Marburg

Filaviviridae

Dengue, Yellow Fever

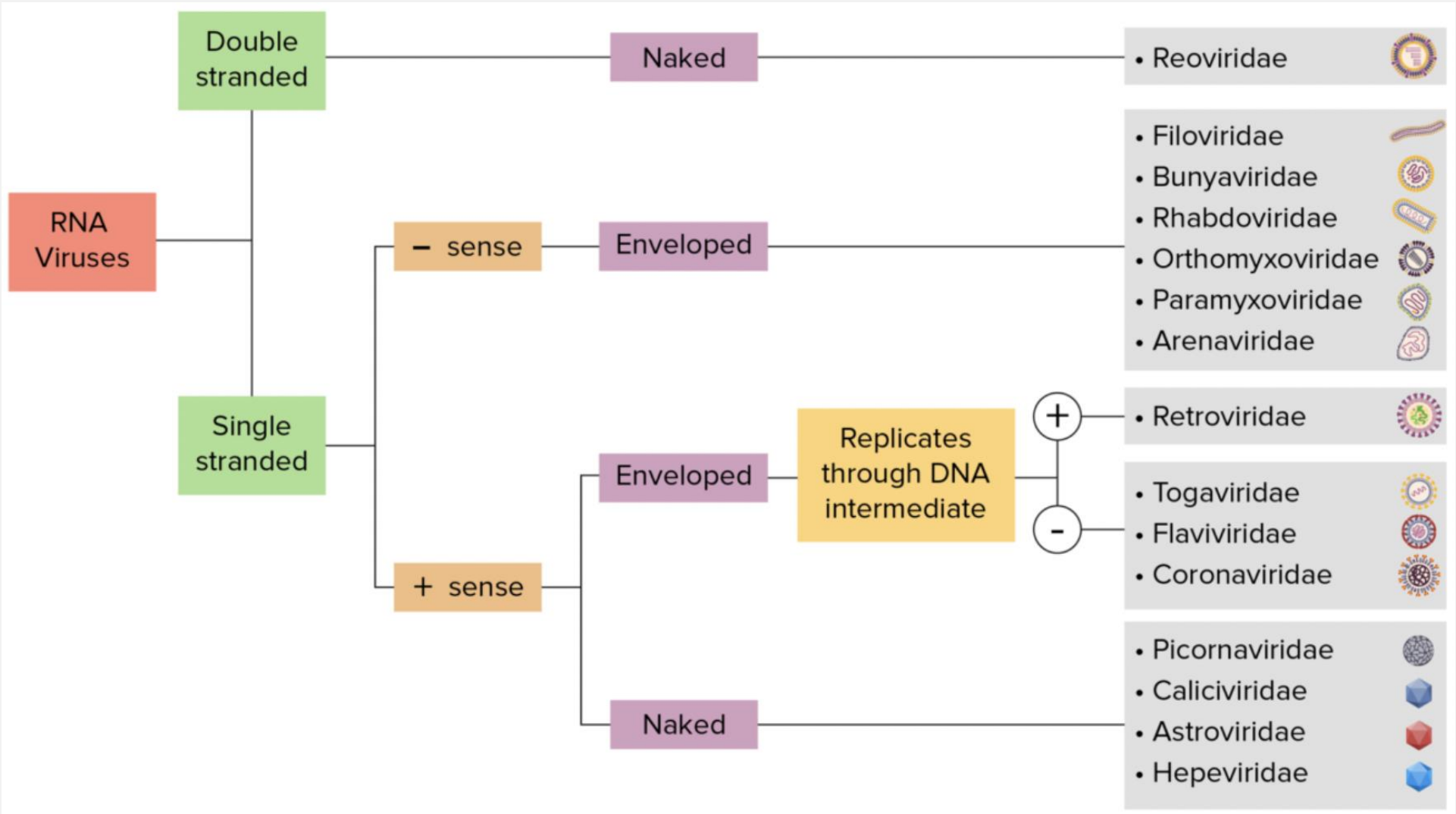



Bunyavirales

Crimean Congo Hemorrhagic Fever

Severe Thrombocytopenic Fever Syndrome:

First in China in 2011 (N Eng J Med 2011)

2010-2018: 7725 cases, CFR: 10% (Clin Infect Dis 2021)

Rift Valley Fever

Hantavirus infection

Sin Nombre virus

Sandly Fever



CCHF Virus

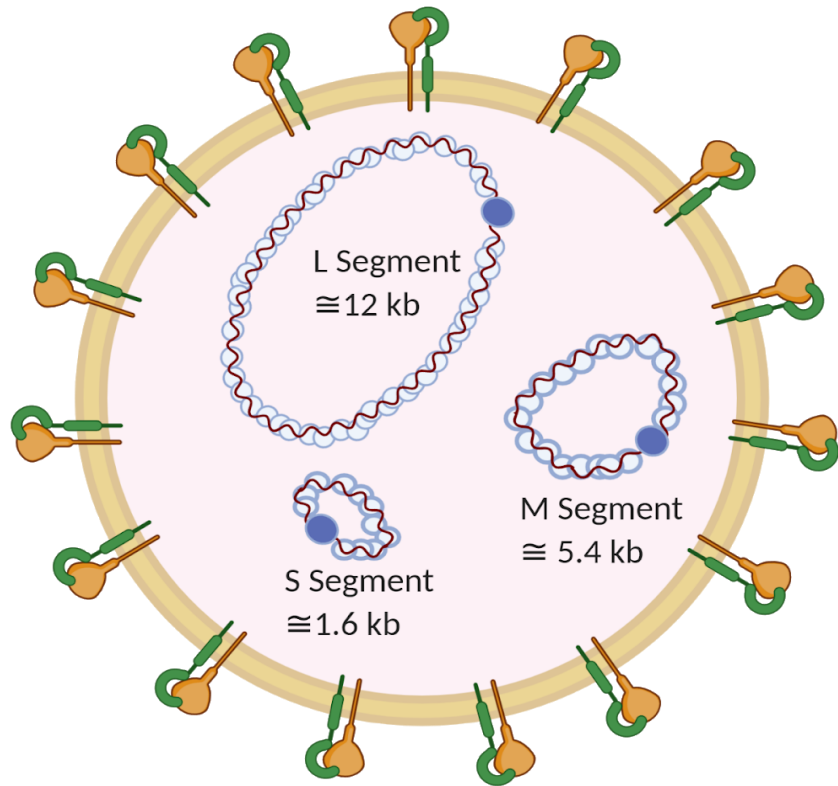

- Glycoprotein N
- Glycoprotein C
- RNA-dependent RNA Polymerase
- Ribonucleoprotein Complex

L, M and S segments

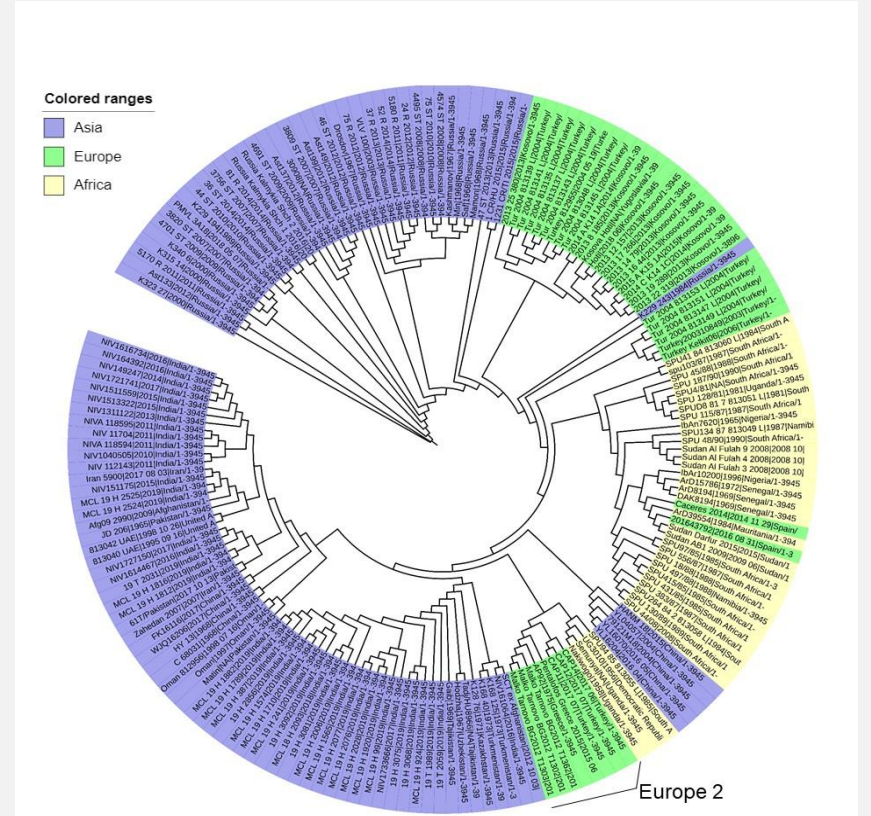

Phylogenetic tree based on L segment:
11 different types



Engineering and structures of CCHFV glycoprotein complexes

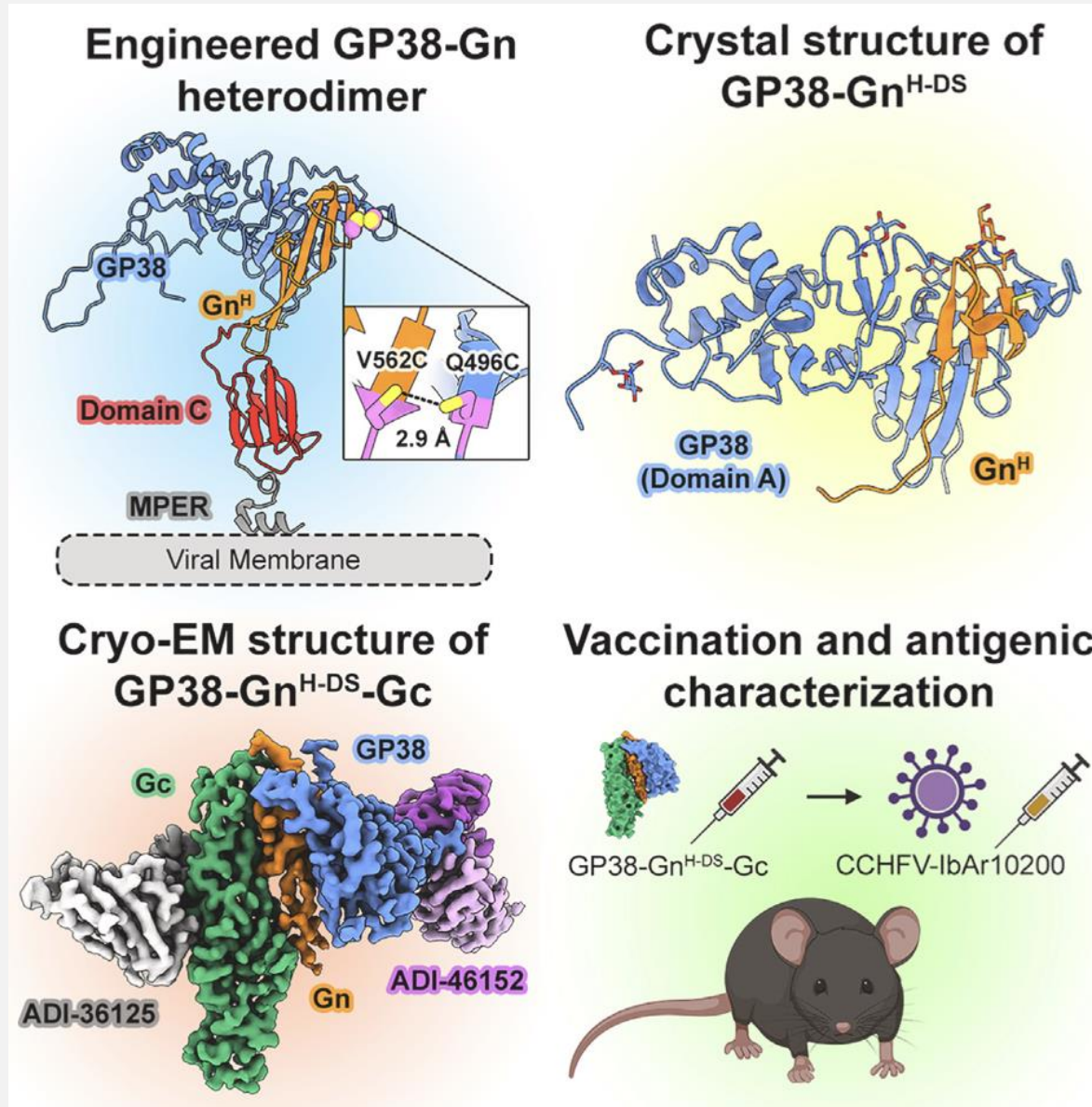



Structure of CCHFV glycoprotein complex

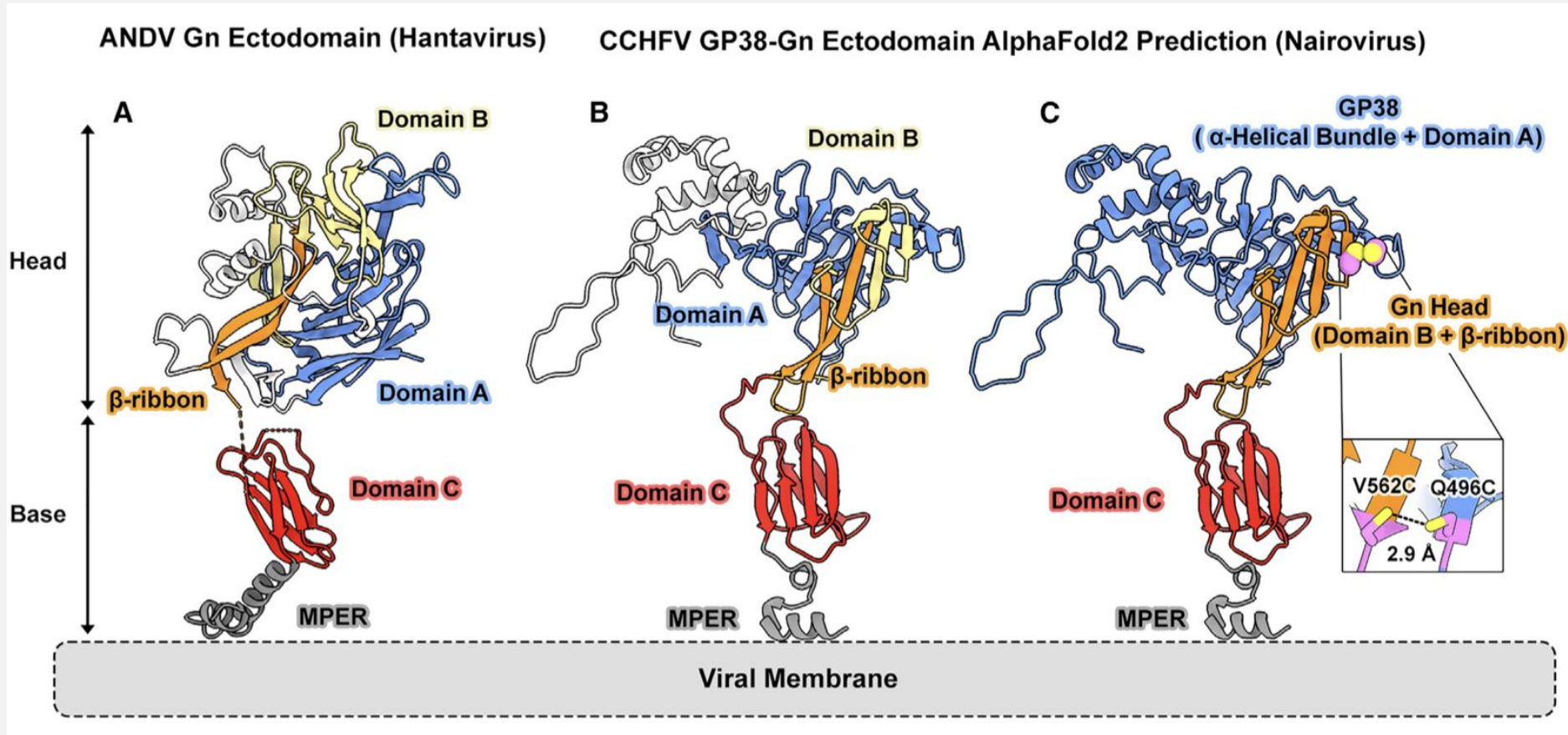

McFadden E, et al. Cell.
2025

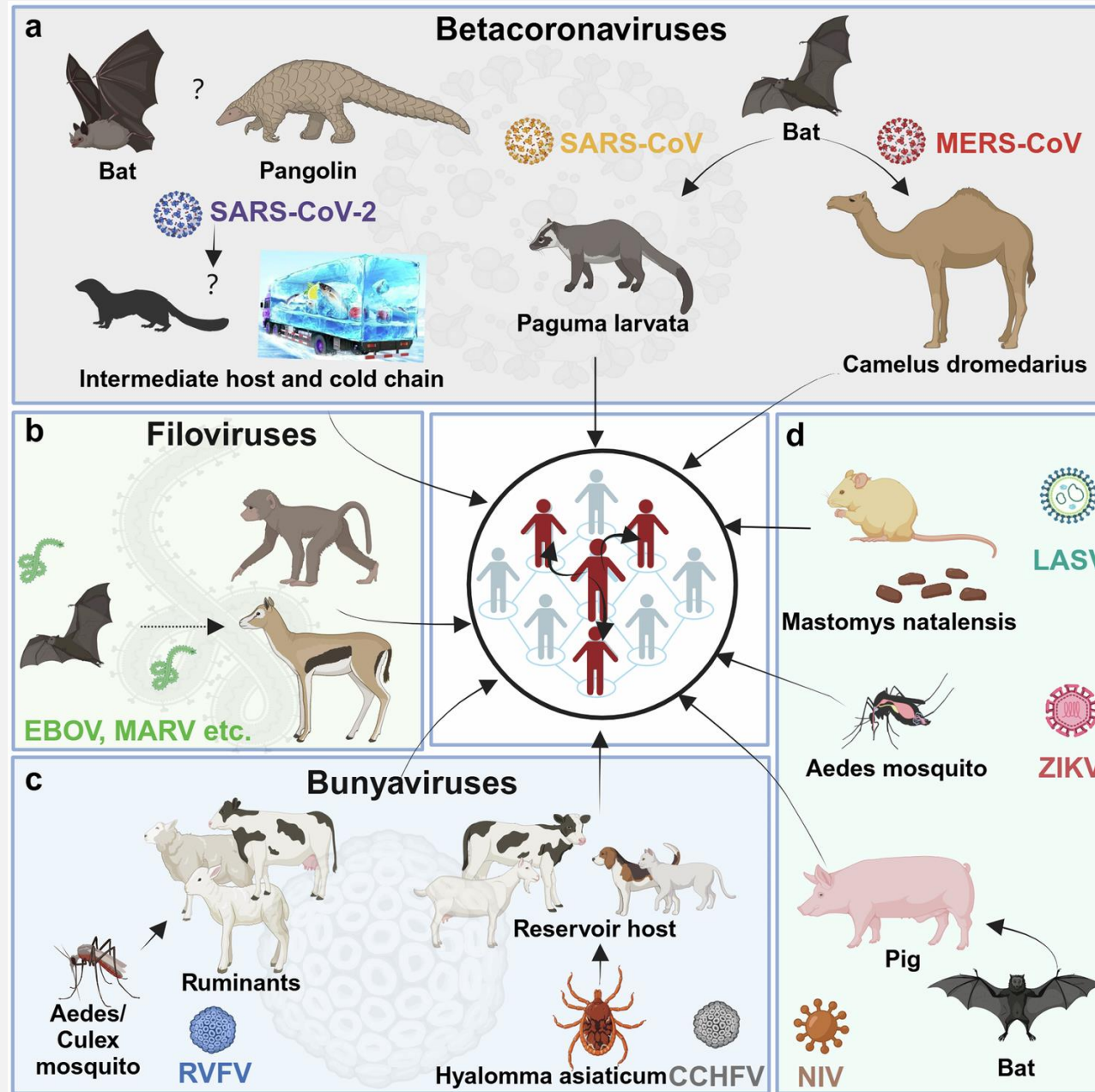

Crimean-Congo Haemorrhagic Fever Geographic Distribution

50° North limit for *Hyalomma* ticks



>30 000 cases
5-40% fatality

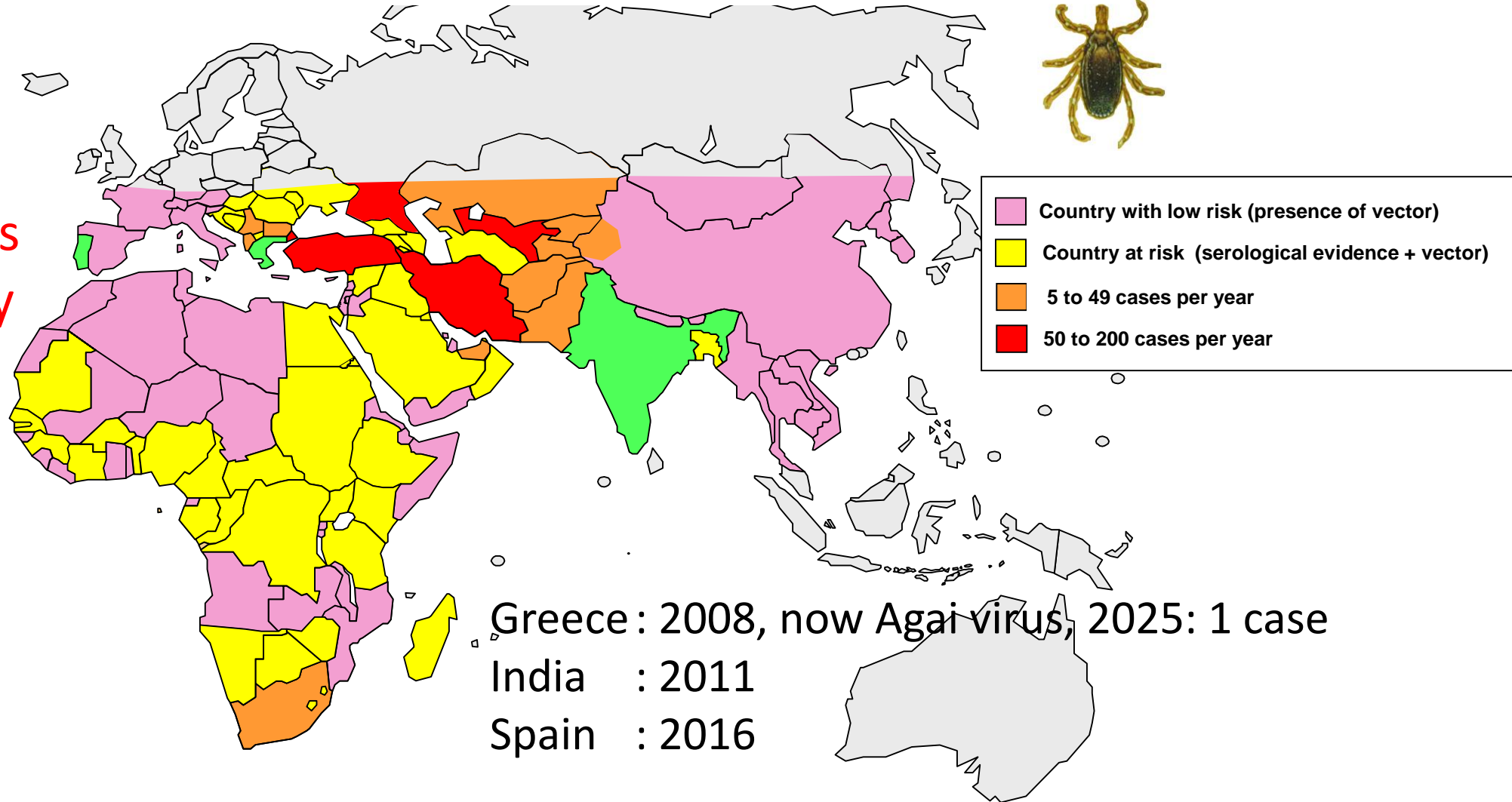

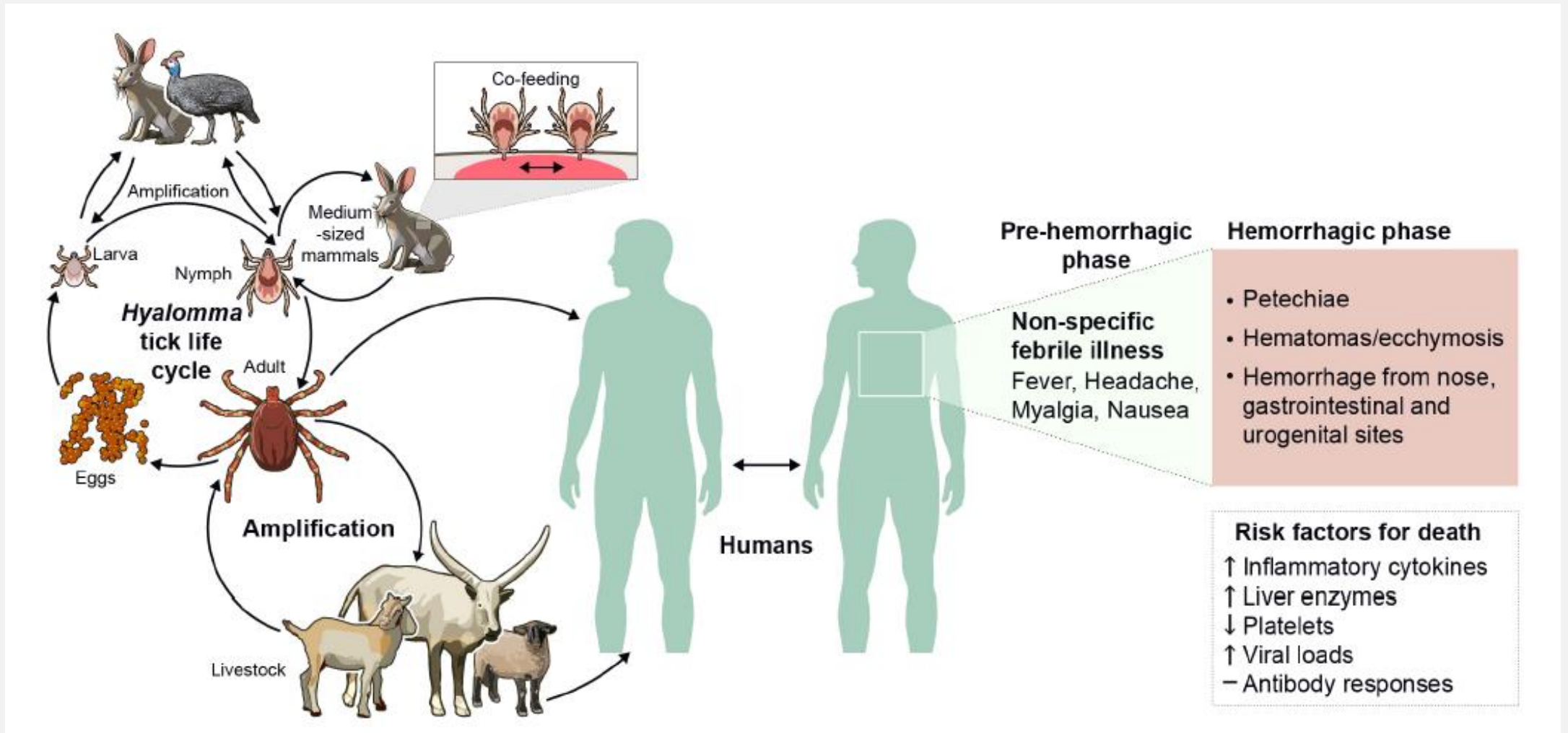



The Course of Infection in animals

Mild clinical symptoms

Described by Shepherd et al in 1980s.

No striking notes in recent outbreaks, since 2000

Viremia

Lasts for 7-10 days in mammals



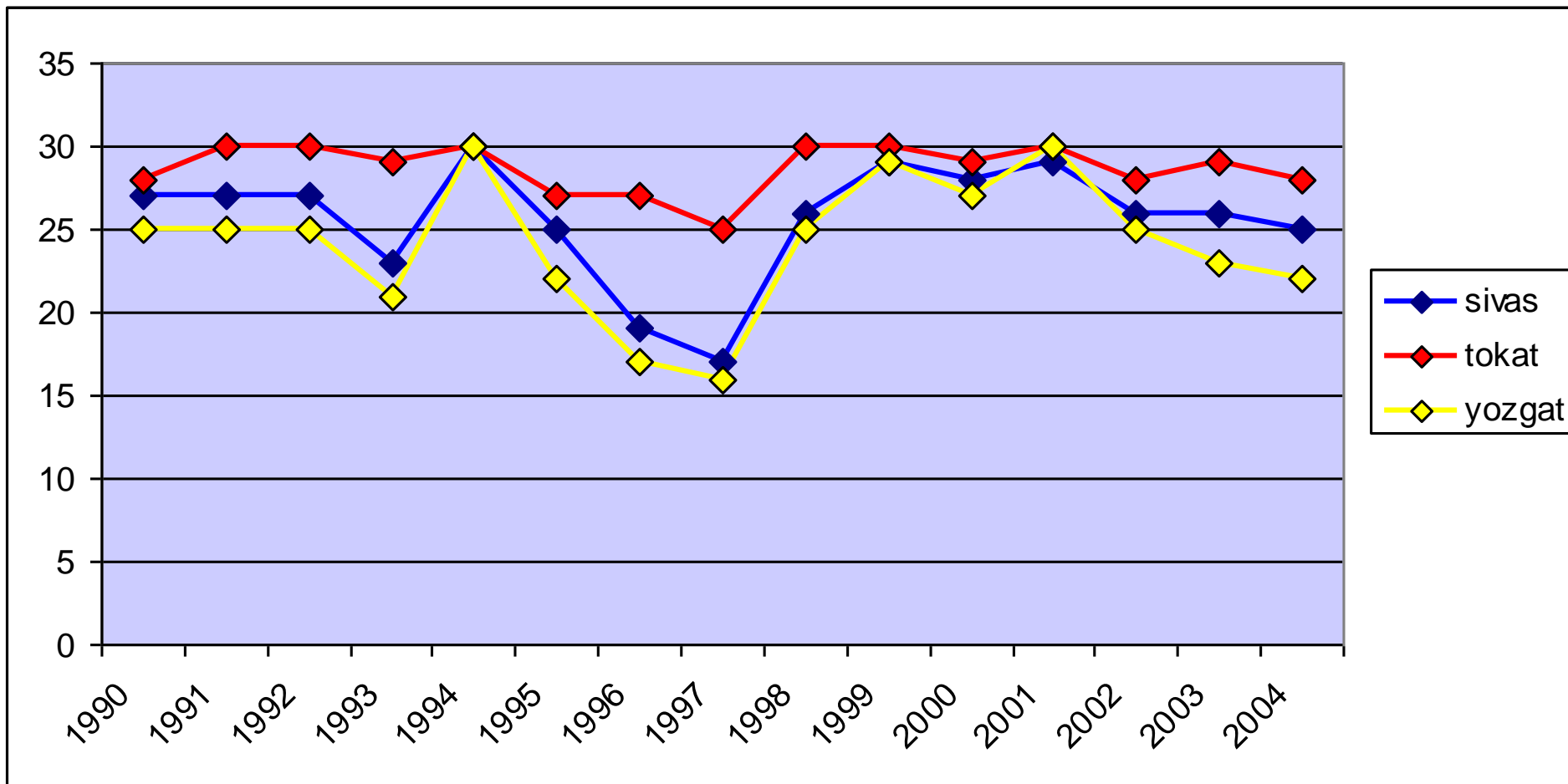

In April (1990-2004), number of days >5 °C

CCHF cases in the Rostov region for 1963-2008

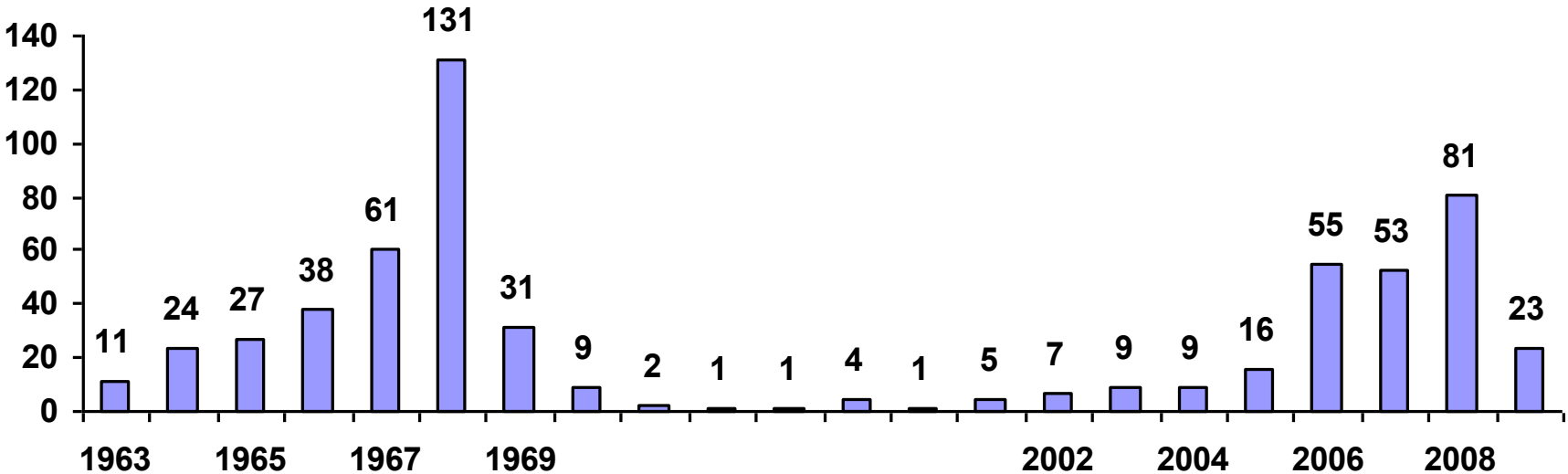

Cold winters in late 1960s; Hoogstral, 1979



Albania, 2006

Changes in Biotic Environment

De-population

Increase in vectors and reservoirs



УЗНАЙТЕСЬ ВСЕХ СТРАН, ОБЪЕДИНИТЕ
ДЛЯ БОРЬБЫ С БОЛЬШЕВИЗМ!

ПРАВДА № 10* (30)
Февраль
1942 г.

Новый порядок землепользования
Дар Адольфа Гитлера русскому народу

Вождь германского народа Адольф Гитлер выдвиг проект о предоставлении земельной реформы и освобождения от советской территории русских областей. Эта реформа является необходимой для экономичного русского крестьянства, которое должно получить всю власть и землю. Этот план Адольфа Гитлера крестьянские Гитлер и обманчивая реформа: вы привносите наем. Колхозы, владения, востановили порядок, общины, владения, крестьянства, своим порядком, Гитлер и обманчивая реформа: вы привносите. Это означает, что крестьяне скоро будут поставлены в условия нормальной работы и нормального существования на своей земле.

Крестьяне!
Германское правительство, освободившее вас от большевизма, решило дать крестьянам землю в беспрепятственном пользовании. В соответствии с этим объявлено особый порядок землепользования. Это означает: **Трудолюбивому крестьянину — своя земля!**

Свободные люди —



на свободной земле!

Re-population

Sudden Exposure



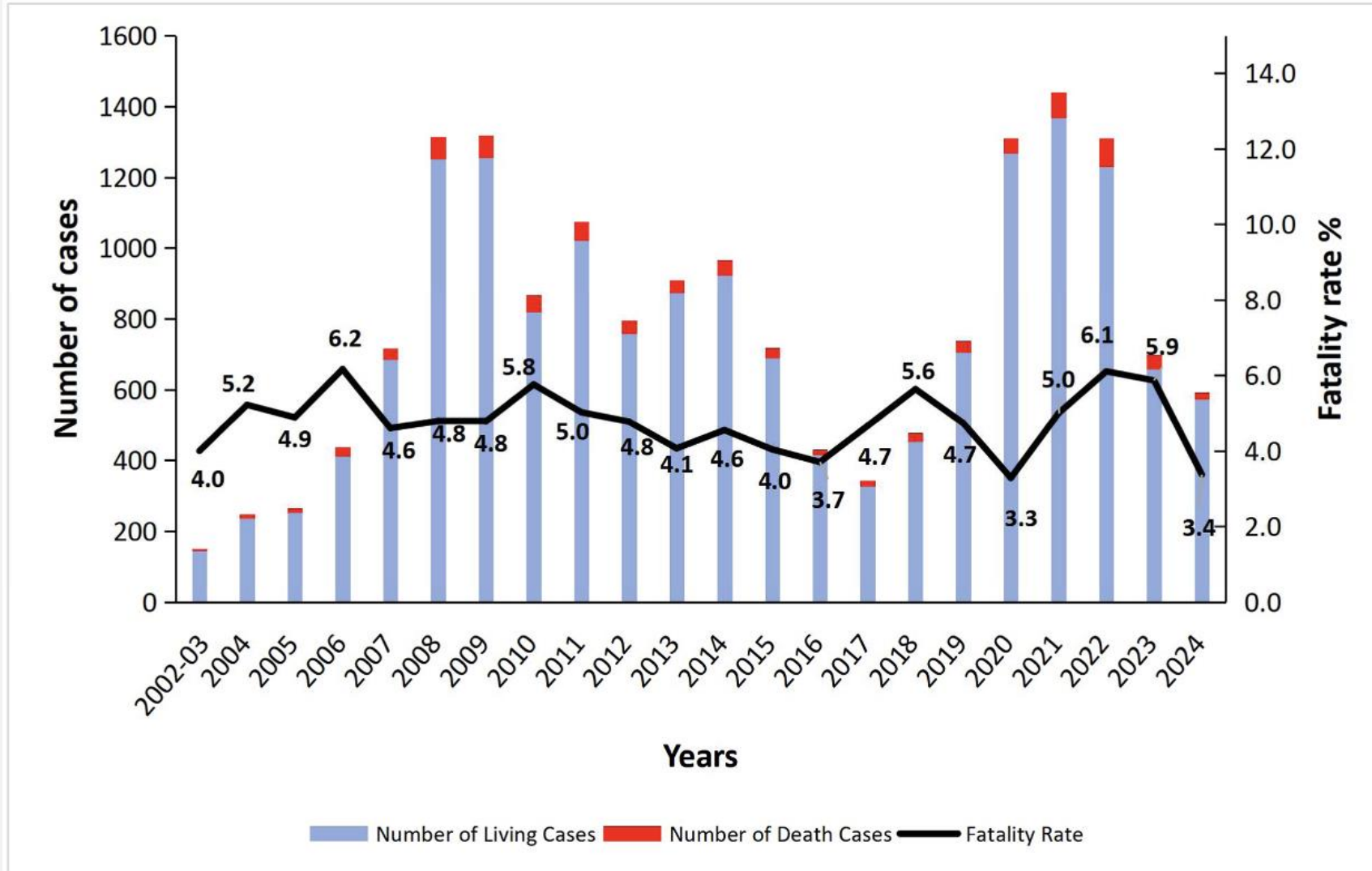

Şahan S, Topluoğlu S, Temel F, Coşgun Y, Öz E, Demirkol ME, Birinci Ş. Evaluation of epidemiological characteristics of Crimean-Congo haemorrhagic fever patients reported to the National Surveillance System in Türkiye, 2011-2024. Acta Trop. 2025



Distribution of Cases in Türkiye

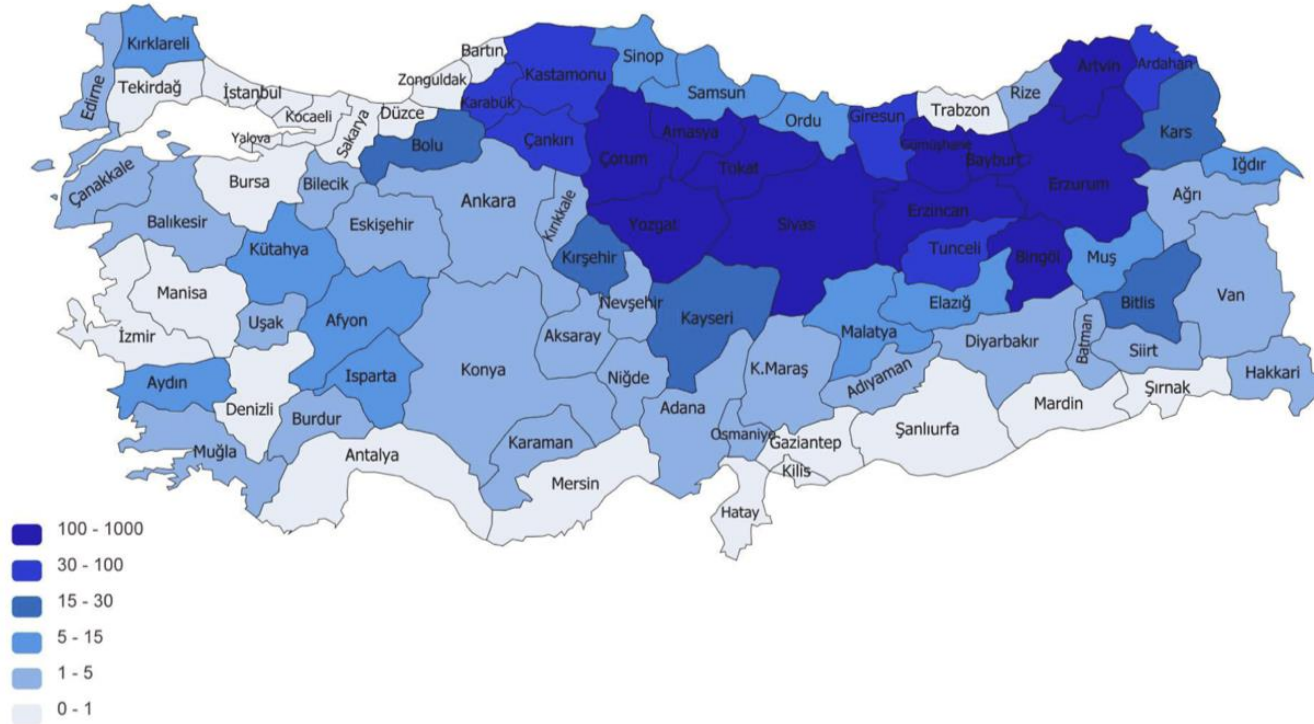
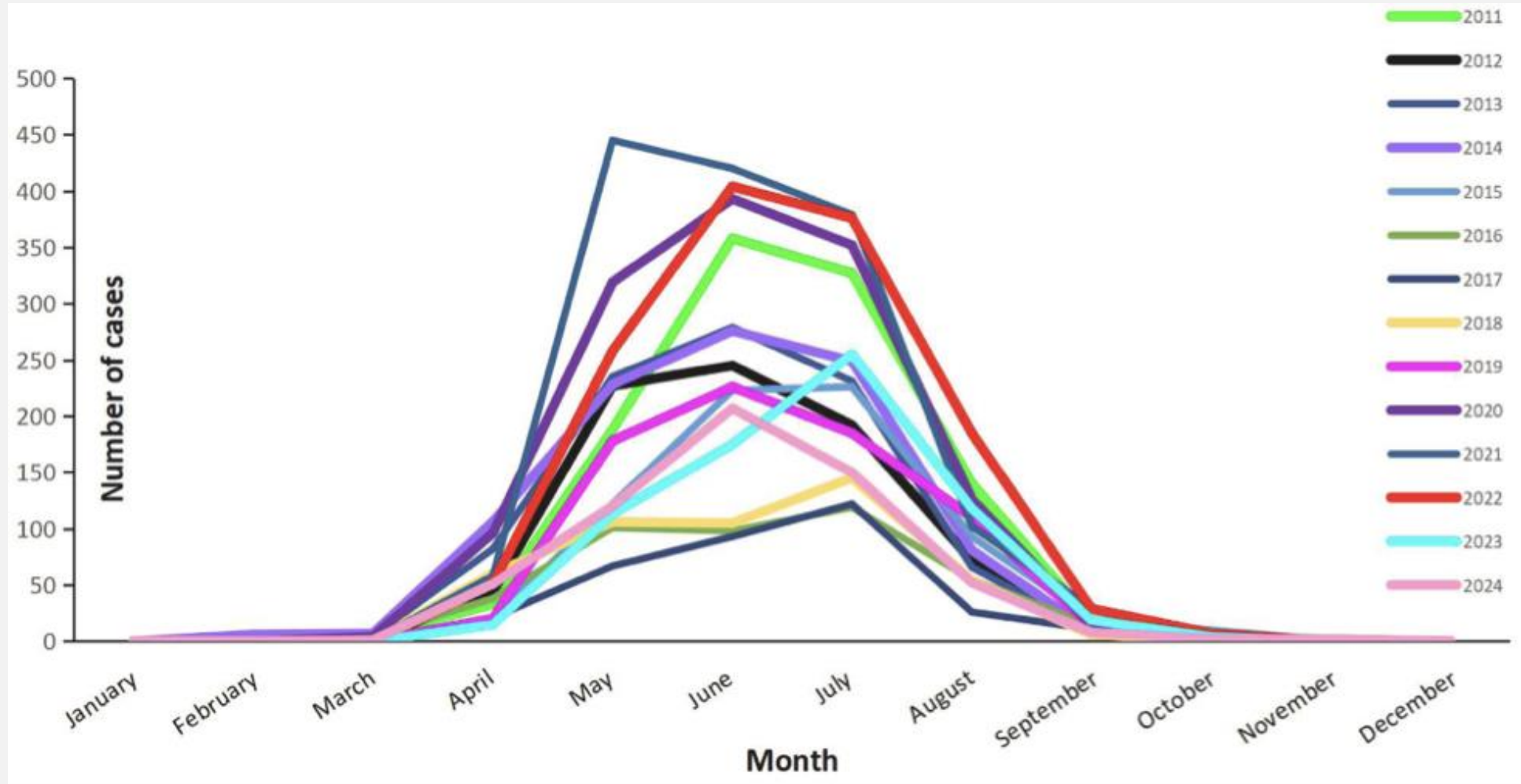

Fig. 3. Incidence rates (per 100,000) of CCHF by province, Türkiye, 2011–2024 A choropleth map showing cumulative case counts per province, with darker shading representing higher incidence. Data aggregated from the national CCHF Information System (2011–2024). Provincial boundaries obtained from the Turkish Statistical Institute.

Şahan S, Topluoğlu S, Temel F, Coşgun Y, Öz E, Demirkol ME, Birinci Ş. Evaluation of epidemiological characteristics of Crimean-Congo haemorrhagic fever patients reported to the National Surveillance System in Türkiye, 2011-2024. *Acta Trop.* 2025



Seasonal Distribution of Cases



Şahan S, Topluoğlu S, Temel F, Coşgun Y, Öz E, Demirkol ME, Birinci Ş. Evaluation of epidemiological characteristics of Crimean-Congo haemorrhagic fever patients reported to the National Surveillance System in Türkiye, 2011-2024. Acta Trop. 2025



Prospective Prediction Tool for Turkey

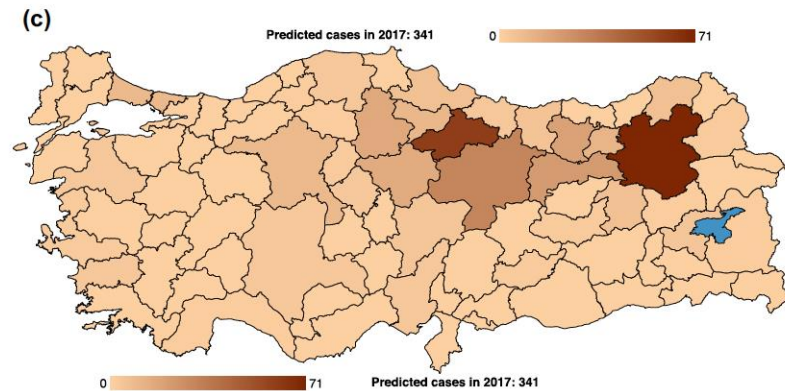
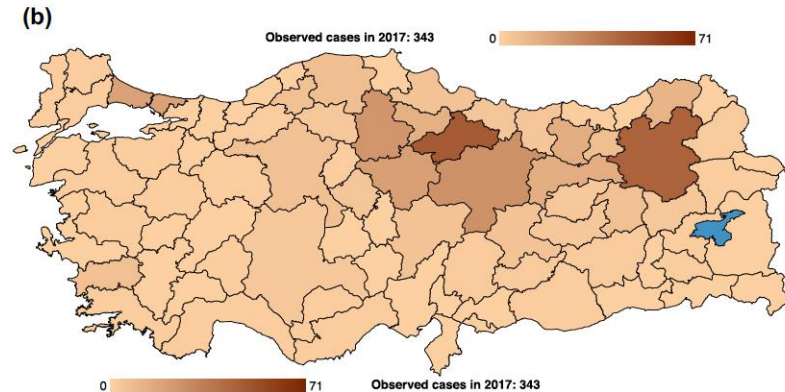
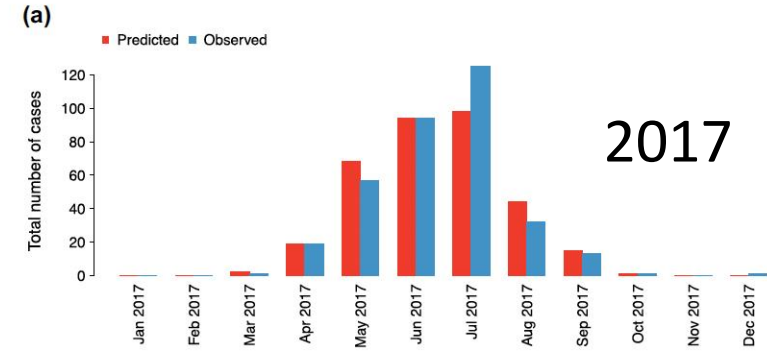
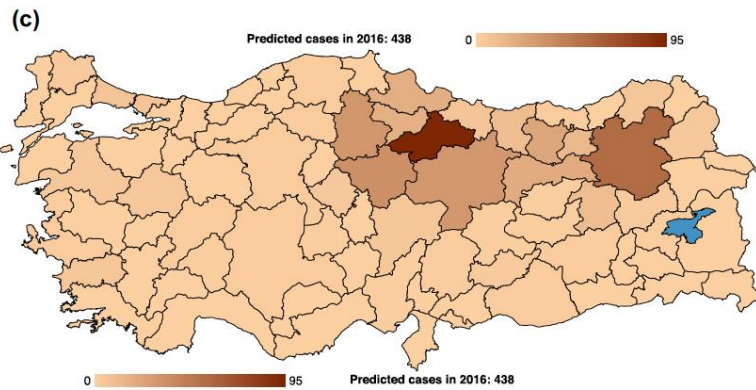
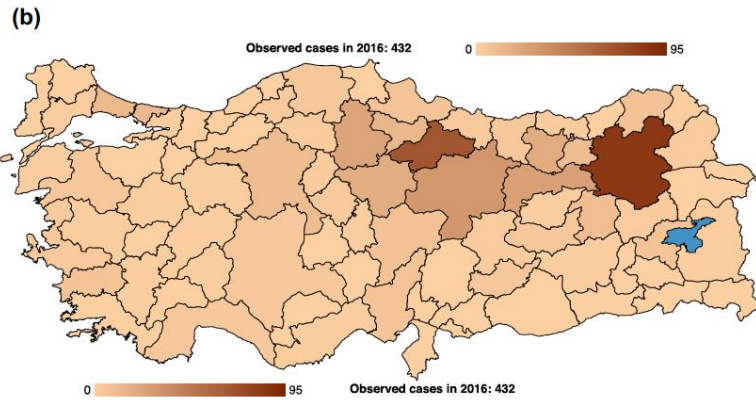
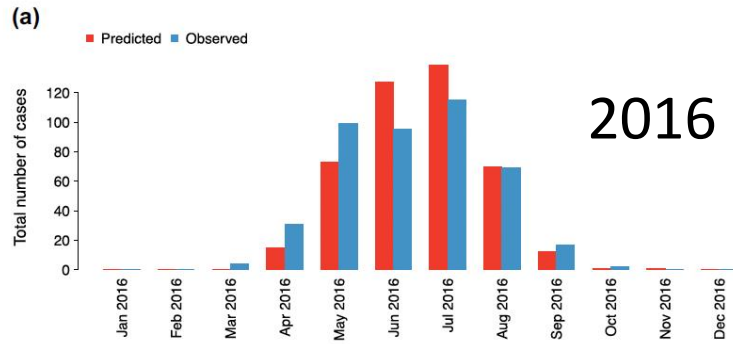



Comparison of observed and model-predicted provincial CCHF case counts in Türkiye for 2021.

Observed CCHF Cases (2021)

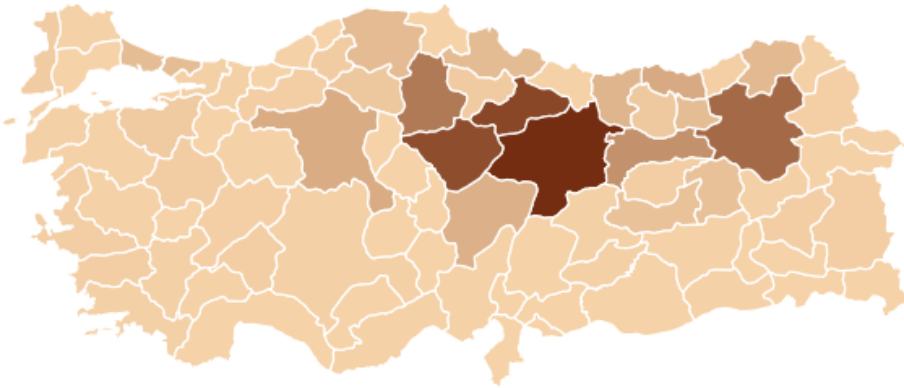

Cases Predicted CCHF Cases (2021)

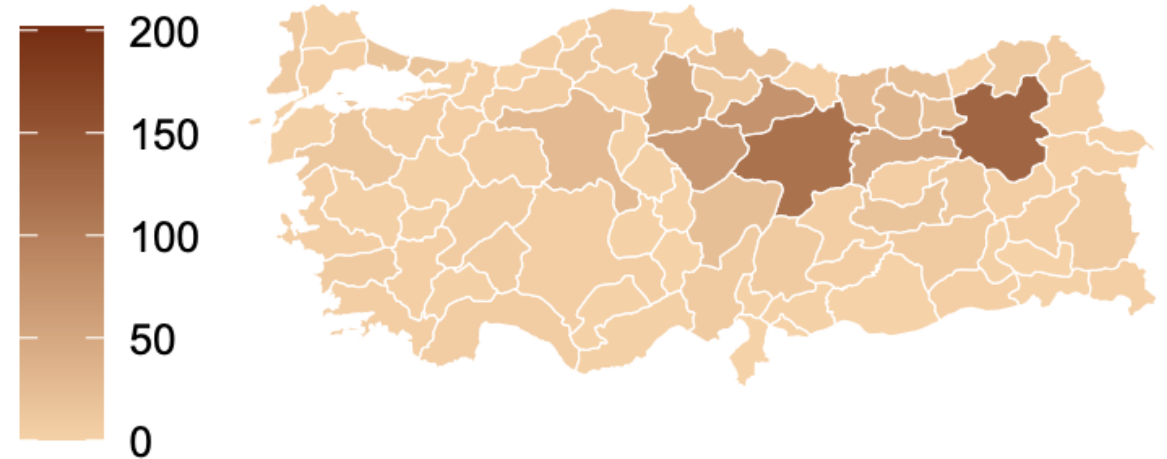

Model forecasts closely approximated observed counts in 2022 and 2024 but substantially underestimated incidence in mobility-affected years of 2020–2021. The largest discrepancy occurred in the Sivas province in 2021, coinciding with documented COVID-19–related reverse migration to rural, tick-endemic areas.

Karanfil Ö, et al. Crimean-Congo Haemorrhagic Fever (CCHF) in Türkiye, 2017–2024: Evolving Dynamics and Implications for Regional Preparedness



Annual geographic distribution of reported Crimean–Congo haemorrhagic fever (CCHF) cases across Türkiye, 2017–2024.

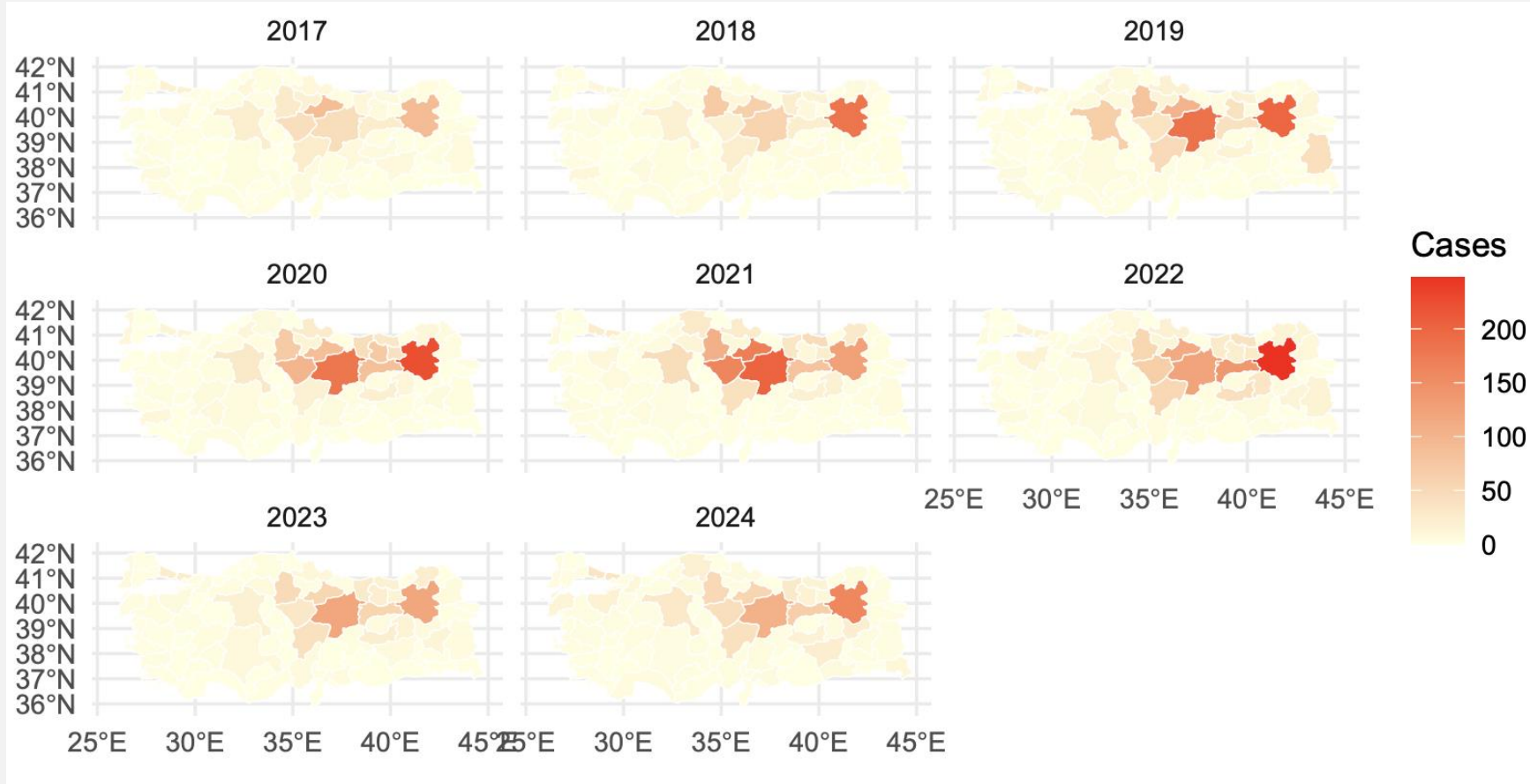

Karanfil Ö, et al. Crimean-Congo Haemorrhagic Fever (CCHF) in Türkiye, 2017–2024: Evolving Dynamics and Implications for Regional Preparedness

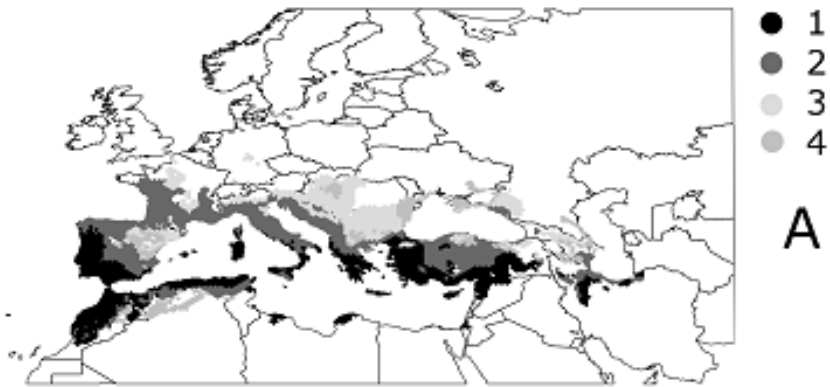

Known records of *Hyalomma marginatum*

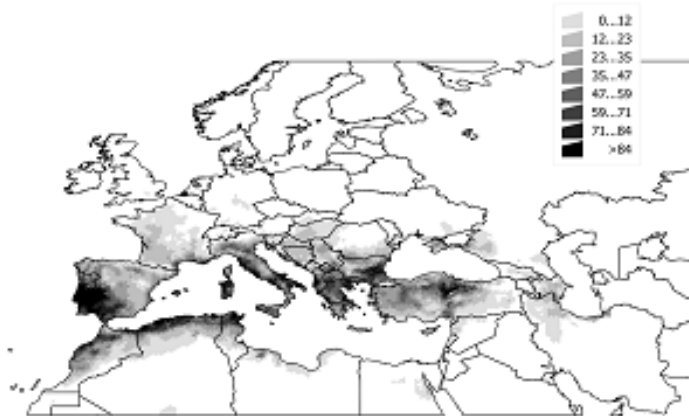

The predicted climate suitability for the tick *H. marginatum* in the area of analysis with current (1970-2000) climate conditions

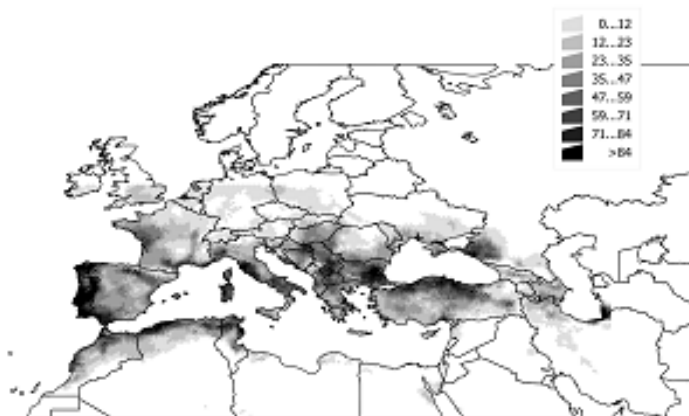

The predicted climate suitability as projected for the year 2050

Estrada-Pena 2009



Crimean-Congo Hemorrhagic Fever Virus in Ticks, Southwestern Europe, 2010

This finding suggests the circulation of CCHFV in southwestern Europe. The close affinity of the strain from Spain with strains circulating in western Africa and the lack of similarity with isolates from eastern Europe suggest the introduction of this virus from nearby countries of northern Africa. Migratory movements of birds could explain the presence of the virus in southwestern Europe because birds are common hosts of immature *H. marginatum*, which was reportedly introduced into Europe through annual migratory flights along the western coast of Africa (10). Because

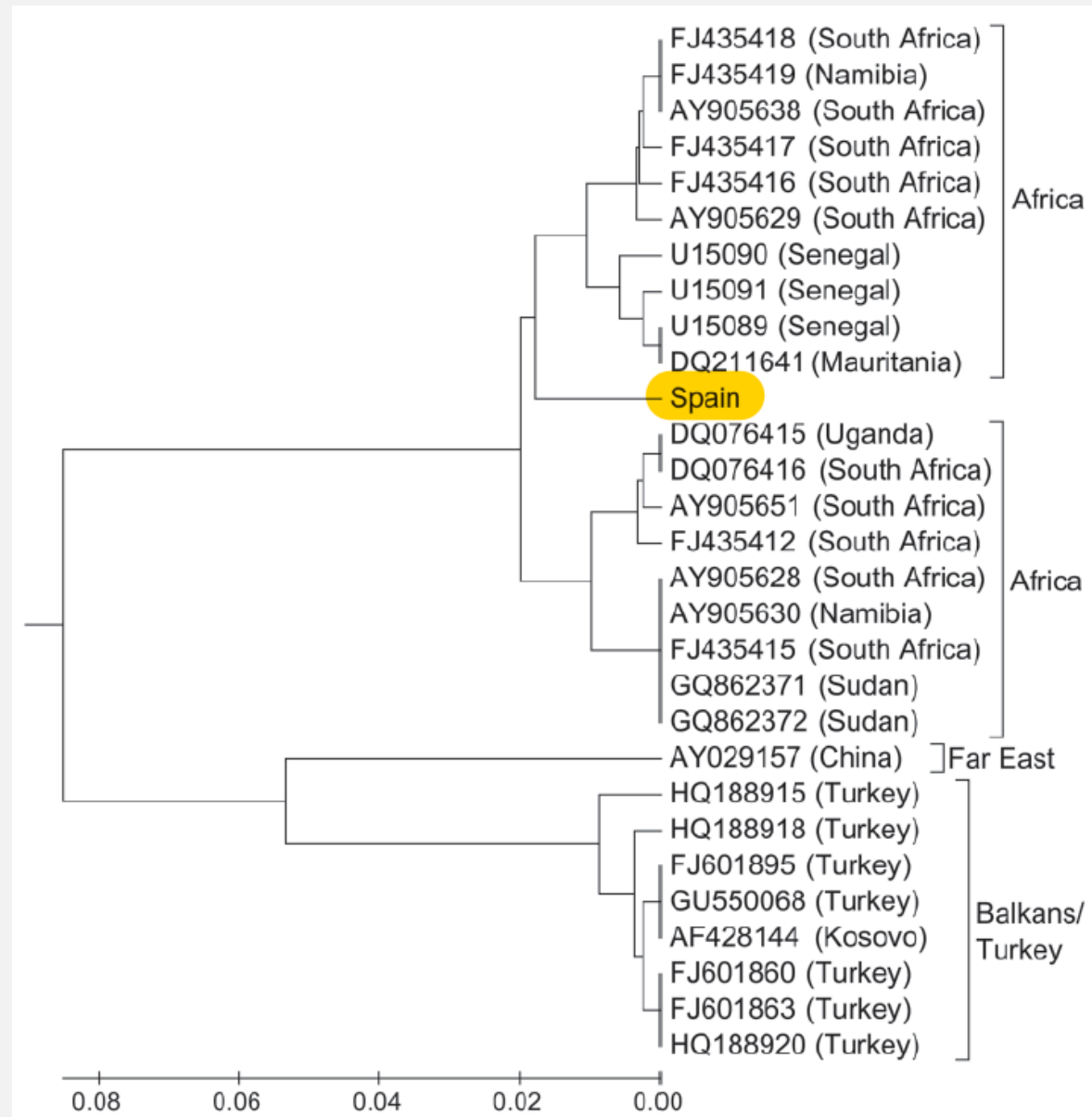

Estrada-Pena, *Emerg Infect Dis* 2010



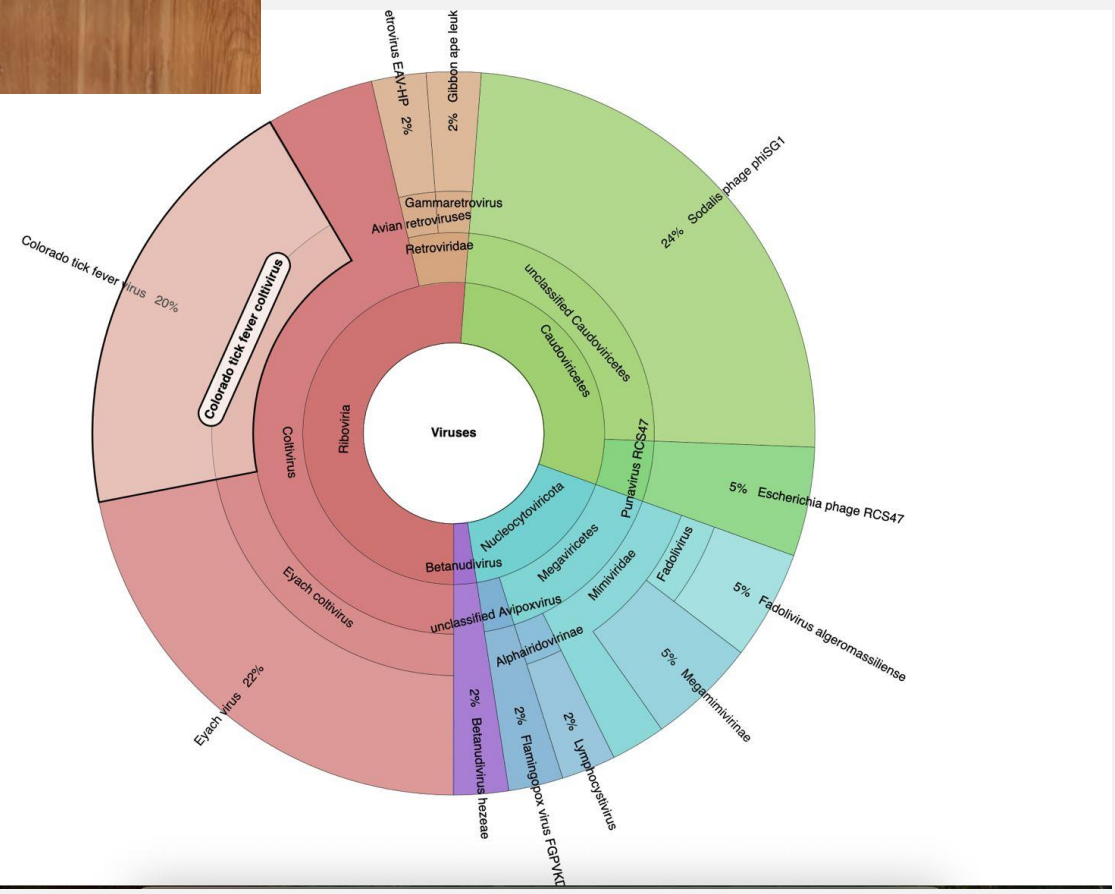



Prevalence of CCHFV in ticks in Western Europe

Table 1. Prevalence of Crimean-Congo hemorrhagic fever virus (CCHFV) in ticks.

Country	Dates	% of Infection Rate (No. of Positive Samples/No. of Analyzed Ticks) ¹		Source	Reference
		PI	MIR (No. of Pools)		
Austria	2018	0 (0/1) <i>H. marginatum</i>	0 (0/1015) (332 pools)	Migratory bird (presumably)	[28]
Corsica (French island)	2014–2015		0 (0/362) <i>H. marginatum</i> (89 pools) 0 (0/518) <i>R. bursa</i> (108 pools) 0 (0/135) <i>H. scupense</i> (135 pools)	Cattle, goat, sheep, horses, dogs, wild boards, mouflons	[29]
Germany	2015	0 (0/1) <i>H. rufipes</i>	1.7 (2/117) <i>H. lusitanicum</i> (12 pools)	Horse	[30]
Spain	2010			Deer	[31]
	2009–2015	0 (0/161) <i>H. marginatum</i>		Asymptomatic patients, birds	[32]
	2013–2015		0 (0/2053) (229 pools) 0 (0/1333) <i>H. marginatum</i> (151 pools) 0 (0/680) <i>H. lusitanicum</i> (74 pools) 0 (0/40) <i>R. bursa</i> (4 pools) 0.5 (1/208) (45 pools)	Vegetation, cattle, sheep	[33]
	2014–2015		0.5 (1/204) <i>H. lusitanicum</i> (NA) 0 (0/2) <i>Dermacentor</i> spp. (NA) 0 (0/4) <i>Rhipicephalus</i> spp. (NA) 1.35 (128/>9500) (3959 pools)	Deer	[34]
	2016–2017		NA <i>H. lusitanicum</i> (NA) NA <i>D. marginatus</i> (NA) NA <i>Rhipicephalus</i> sp. (NA)	Wild or domestic animals ²	[35]
	2011–2015	2.78 (44/1579) 4.0 (43/1079) <i>H. lusitanicum</i> 0.4 (1/238) <i>H. marginatum</i> 0 (0/46) <i>Rhipicephalus</i> spp. 0 (0/3) <i>I. ricinus</i> 0 (0/1) <i>Dermacentor</i> sp. 0 (0/212) not identified 21.0 (129/613)		Vegetation, deer, fallow deer, red fox, cattle, sheep, wild board ³	[36]
	2017	20.2 (119/589) <i>H. lusitanicum</i> 41.7 (10/24) <i>D. marginatus</i>		Red deer, wild boar, fallow deer, roe deer	[37]
	2017		0.5 (7/1356) (452 pools) ⁴	Vegetation	[38]
UK	2018	0 (0/1) <i>H. rufipes</i>		Horse	[39]
	2018	0 (0/1) <i>H. marginatum</i>		Vegetation ⁵	[40]

H. marginatum: *Hyalomma marginatum*; *R. bursa*: *Rhipicephalus bursa*; *H. scupense*: *Hyalomma scupense*; *H. rufipes*: *Hyalomma rufipes*; *H. lusitanicum*: *Hyalomma lusitanicum*; *D. marginatus*: *Dermacentor marginatus*; *I. ricinus*: *Ixodes ricinus*; ¹ Total infection rate [PI: Prevalence of infection (data from individual ticks), MIR: Minimum infectious rate (data from pools)], and corresponding of each tick species analyzed; ² All positive samples corresponded to ticks collected from wildlife, mainly *H. lusitanicum* from deer; ³ Positive samples were collected from deer ($n = 41$) and cattle ($n = 3$); ⁴ The majority of them (80%) corresponded to *H. lusitanicum*; ⁵ The tick was crawling on the leg of a man; NA: Not available.

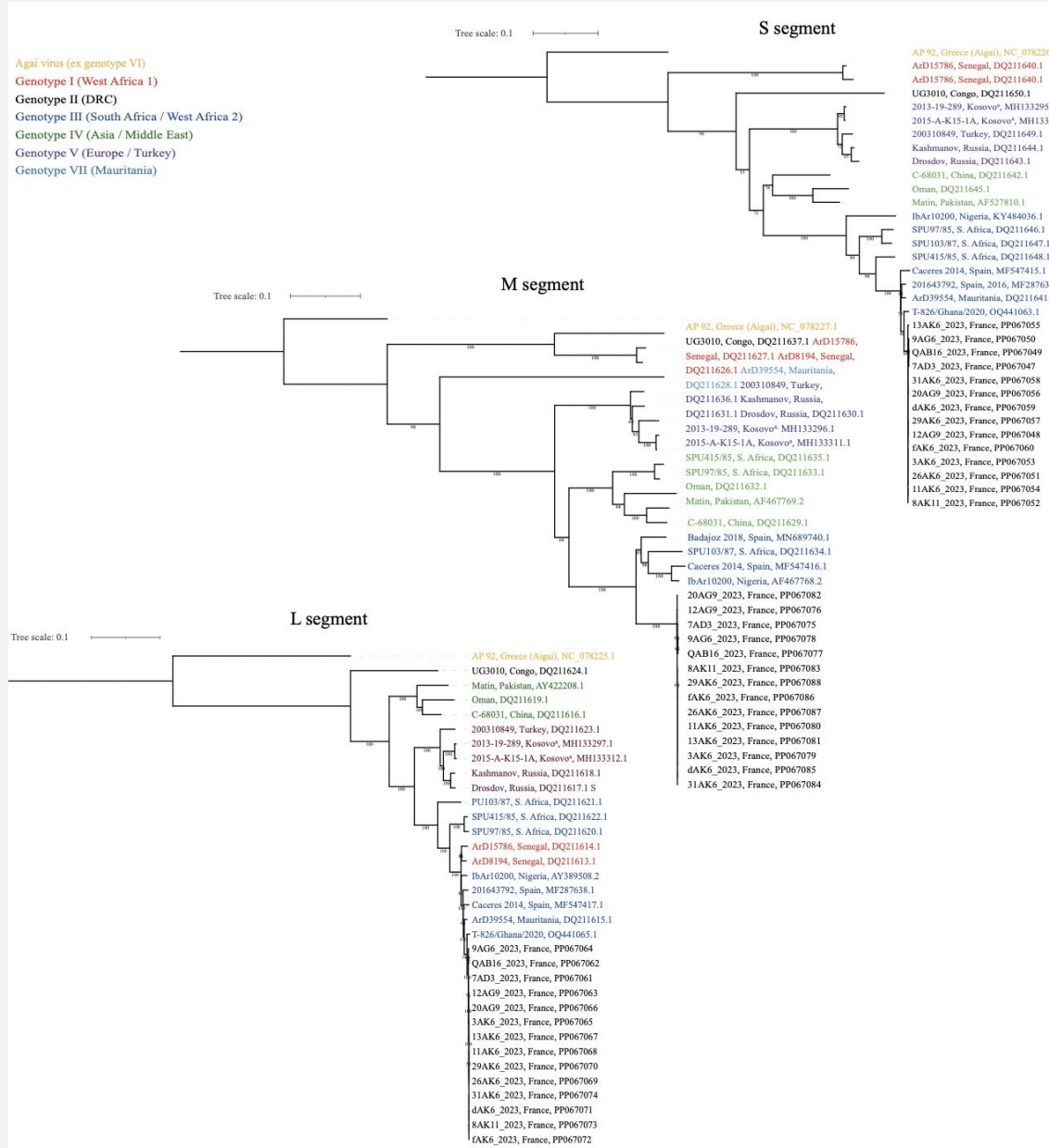

- Agai virus (ex genotype VI)
- Genotype I (West Africa 1)
- Genotype II (DRC)
- Genotype III (South Africa / West Africa 2)
- Genotype IV (Asia / Middle East)
- Genotype V (Europe / Turkey)
- Genotype VII (Mauritania)

Bernard C, et al.. Euro Surveill. 2024



CCHF virus in ticks collected from cattle, Corsica, 2023

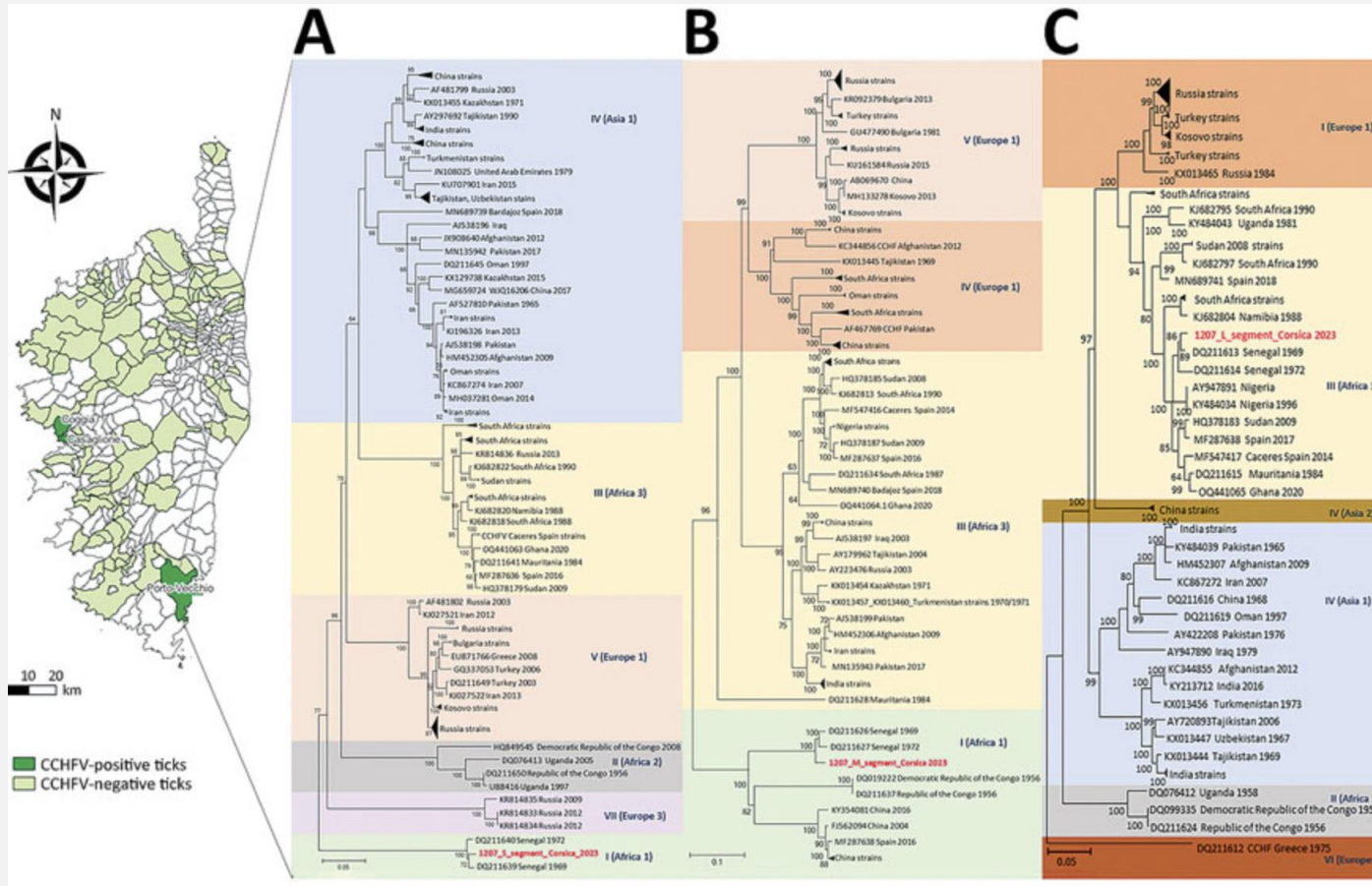

- *Hyalomma marginatum* (most likely the source) in Southeastern and central western parts of Corsica.
- CCHF virus **African genotype I**
- Multiple CCHFV-positive ticks were found on the same animal (cattles).
- CCHFV strains circulating in Corsica and Spain have distinct origins.
- Migratory birds via two different ways from Africa

Kiwan P, Masse S, Piorkowski G, Ayhan N, Gasparine M, Vial L, et al.. Emerg Infect Dis 2024



CCHF virus in *Hyalomma marginatum* ticks in Southern France (2023)

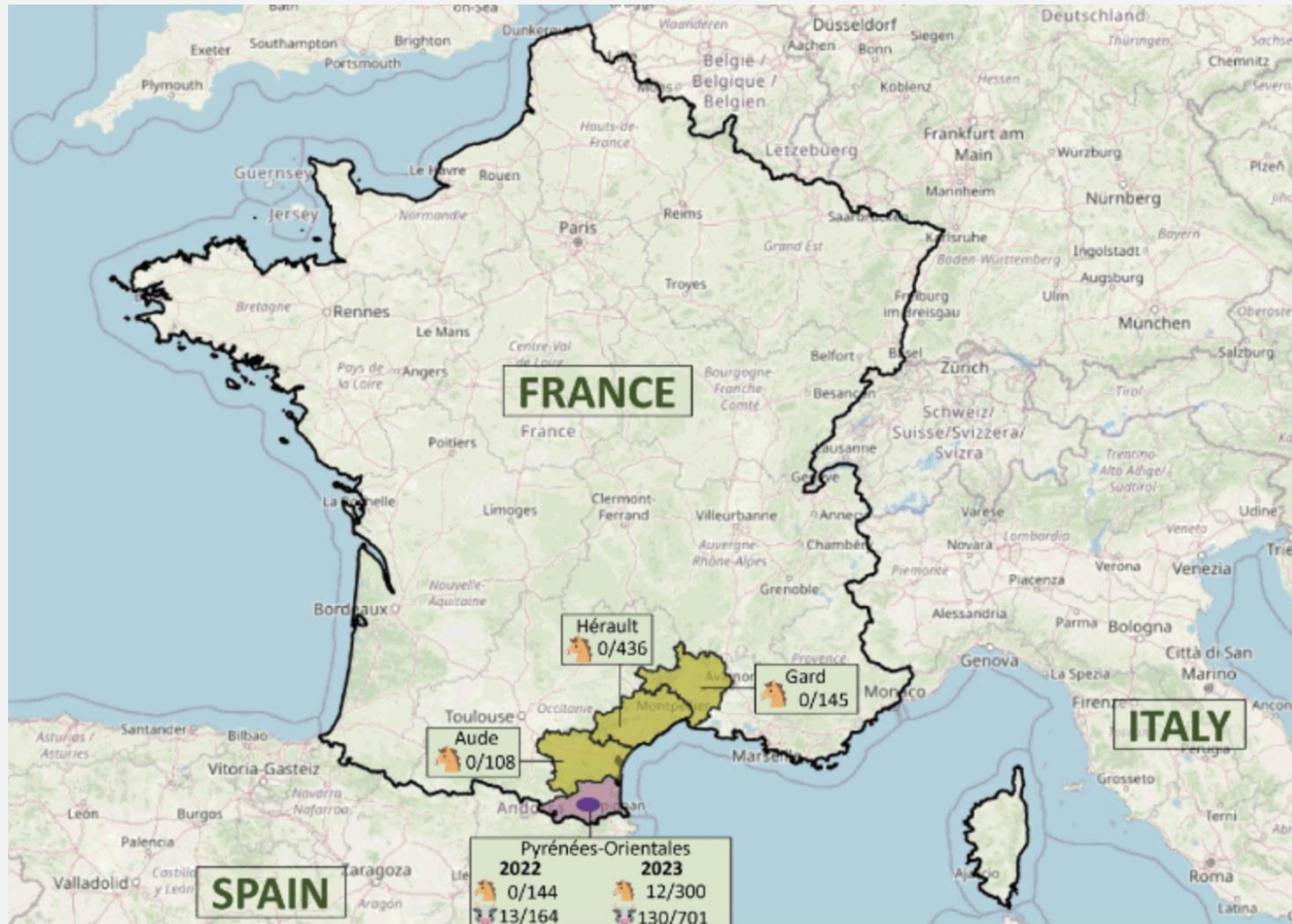

2022: 13/997 (1.3%) ticks
All from the same cattle farm in Pyrénées-Orientales

2023: 142/ 1,001 (14.2%)
H. marginatum ticks were positive for CCHFV.

in Pyrénées-Orientales, 15 cattle farms, 3 farms with cattle and horses 3 farms with horses.

Bernard C, et al.. Euro Surveill. 2024



Cases of Crimean-Congo haemorrhagic fever in North Macedonia, 2023

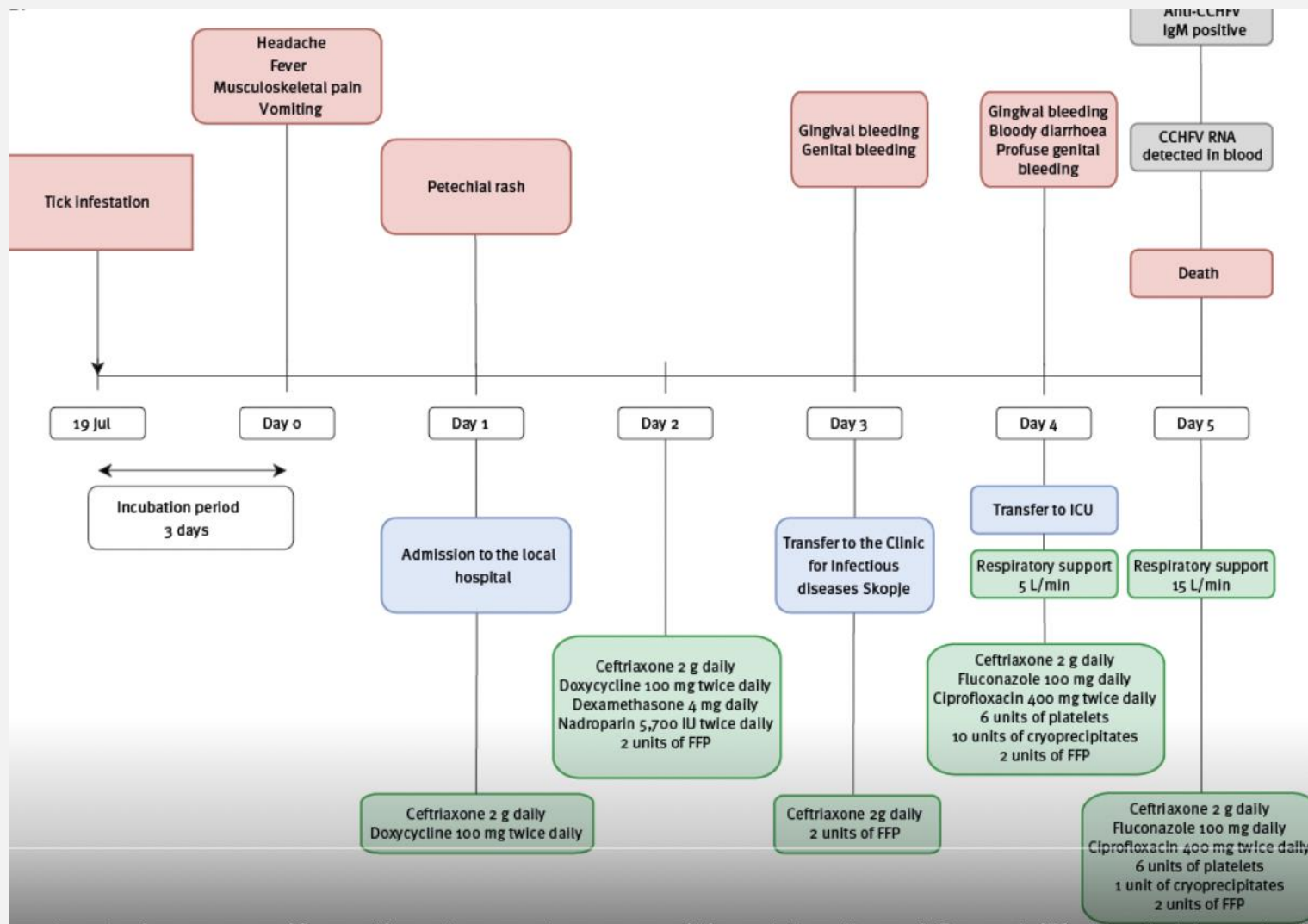

Case 1 in a rural area of the eastern part of North Macedonia, died.

Case 2: healthcare worker.

Contact monitoring 1/67 +

(PPE) including gloves, mask, apron and face shield were used. The exposure could have occurred during possible improper removal of the PPE.

Case 3: from another region of the country, with no epidemiological link to the confirmed cases or identified contacts from contact tracing, was admitted to our clinic.



CCHF in Europe: Total cases since 2013

	Bulgaria	Spain	Portugal	Macedonia	Greece	Total
2013	2/8	1				2/9
2014	1/8 + 1 (UK)					1/9
2015	2/4					2/4
2016	4	1/2				1/6
2017	2					2
2018	1/6 + 1 (GR)	1/2				2/9
2019	2					2
2020	1	1/3				1/4
2021		2				2
2022	1/2	1/2				2/4
2023	3	1		1/3		1/7
2024	1	2/4	1/1			2/6
2025		3			1/2	1/5
Total	7/43	6/17	1/1	1/3	1/2	13/63 (23%)

ECDC: end of 2025



The Presentation of a Case

37 years old male came to the outpatient clinic.

He has myalgia, sometimes high fever.

The first step is CBC

Platelet count	78,000/ml
Leukocyte count	3800/ml
CRP	30
Procalcitonin	0.8

The History of tick bite, location

Differential Diagnosis

- COVID-19
- CCHF
- West Nile
- Chikungunya
- Zika
- Sandfly
- Hanta virus
- Influenza
- Dengue
- EBV

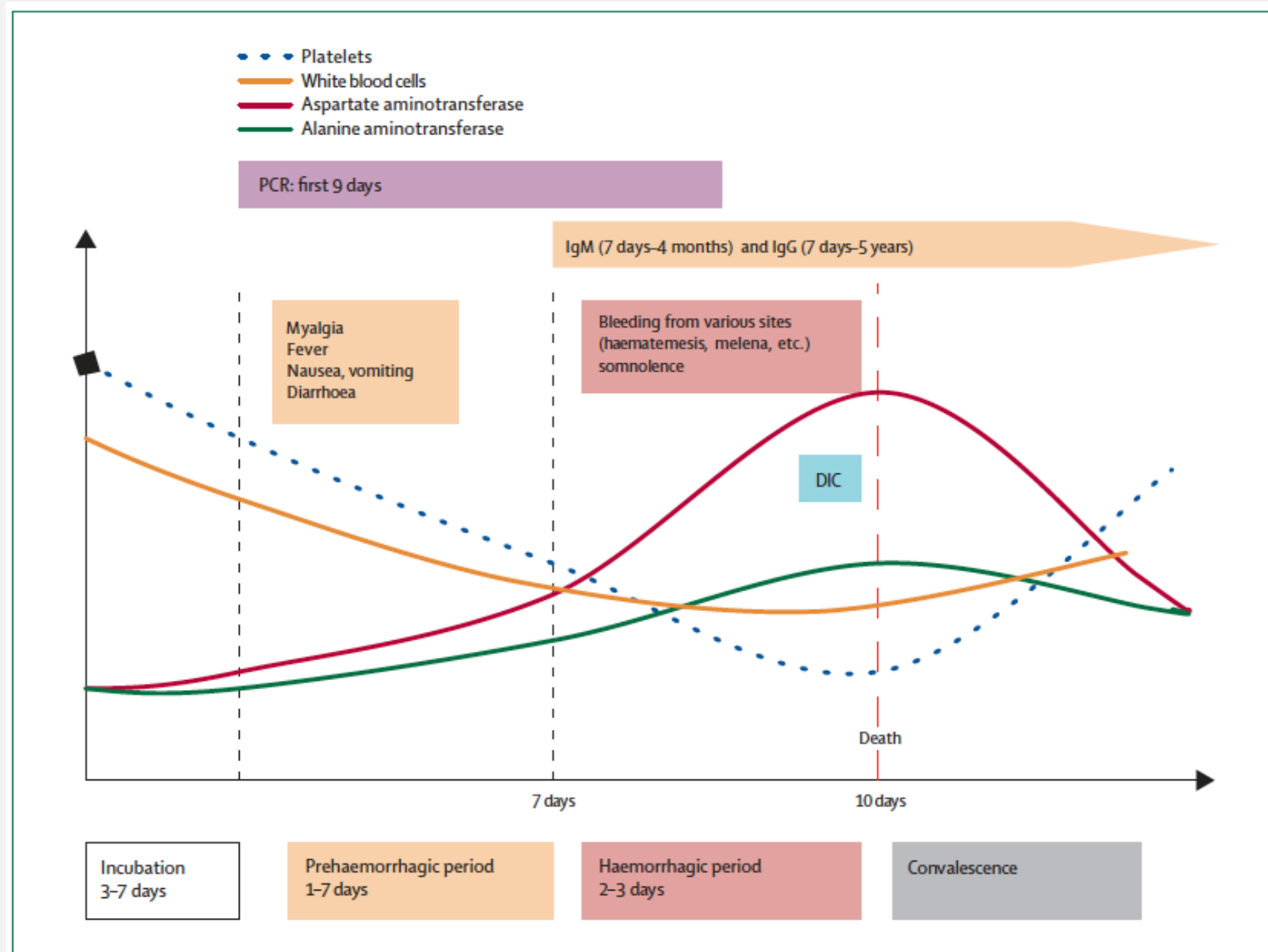
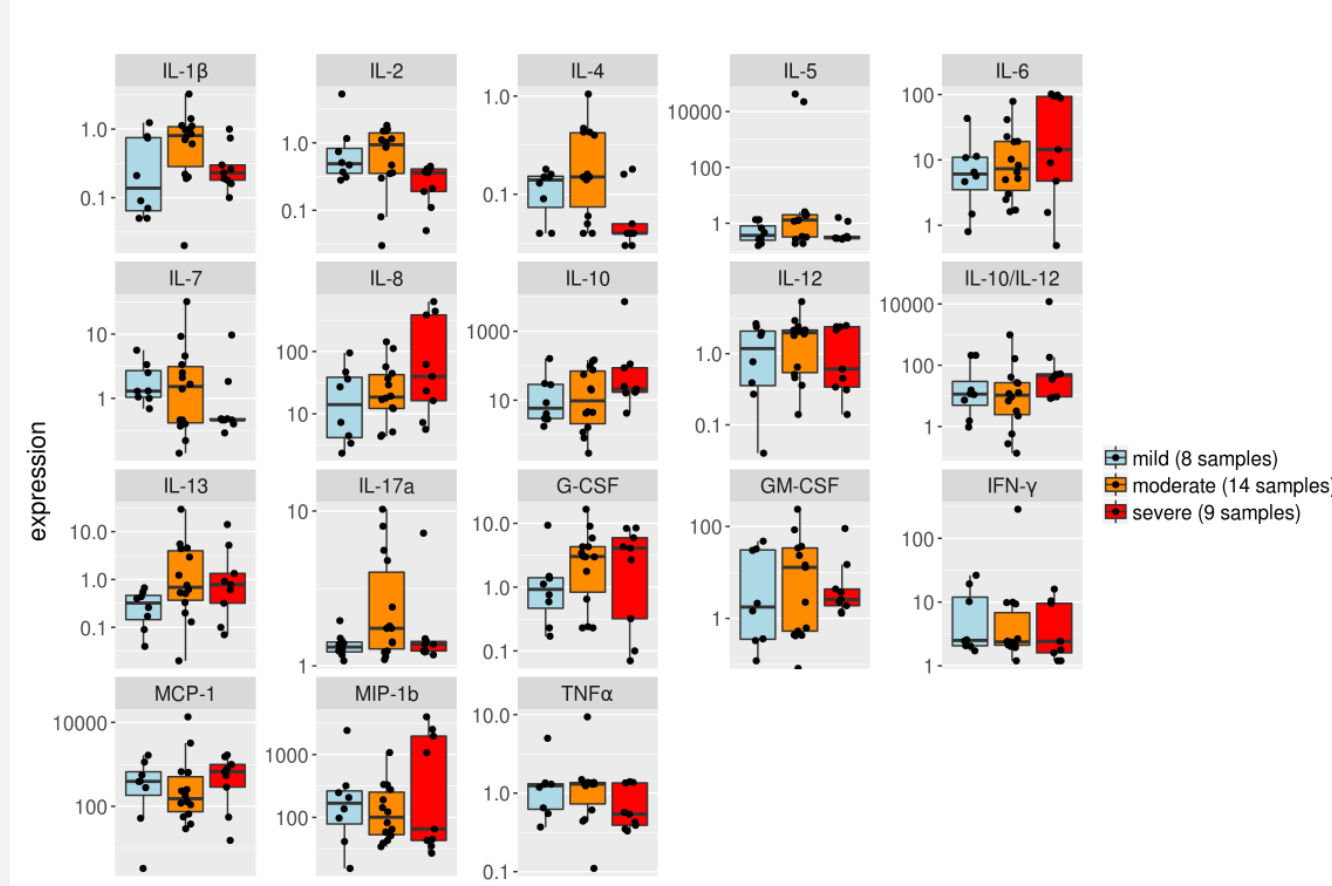

Figure 3: Clinical and laboratory course of CCHF
DIC=disseminated intravascular coagulation.



Cytokine Levels of Different Severity Groups for First Five Days



CCHF: J Med Virol 2017

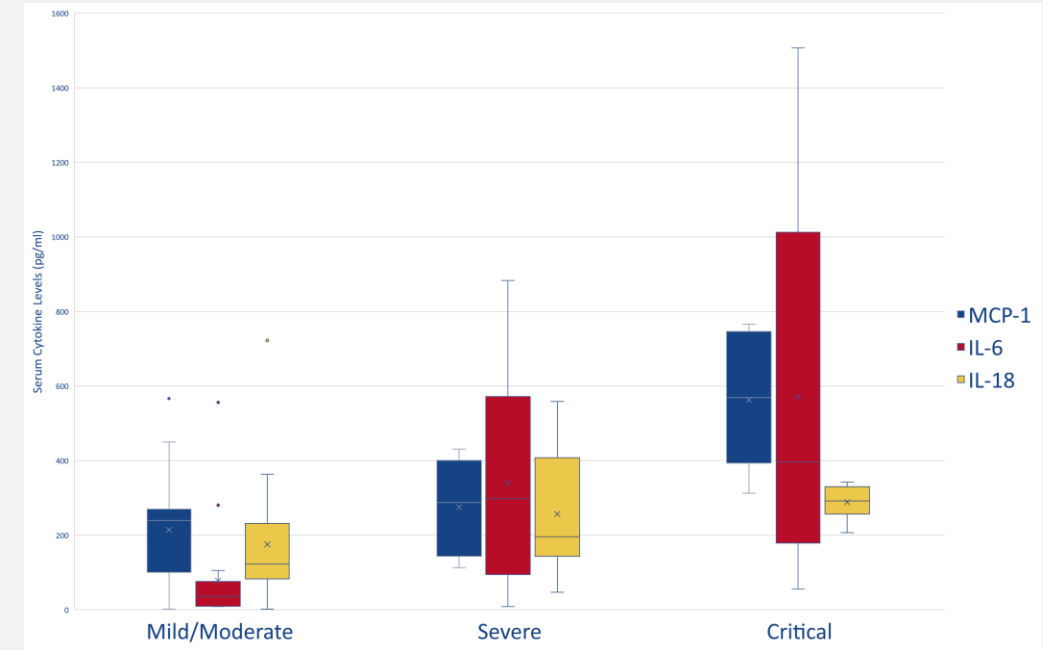

COVID-19: ECCMID 2022



Pathogenesis of Ebola

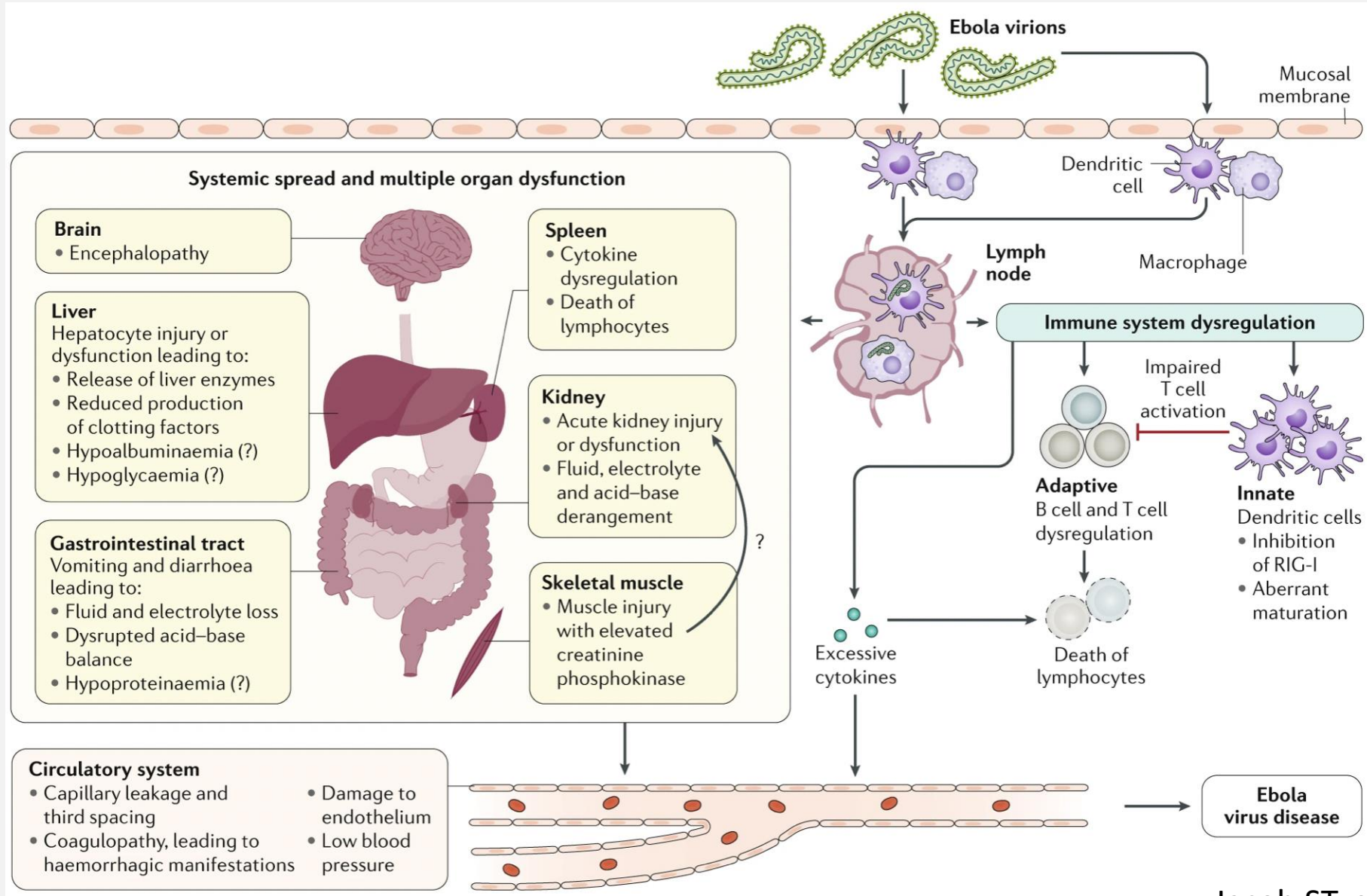

Jacob ST, et al. Nat Rev 2020



Cytokine Storm

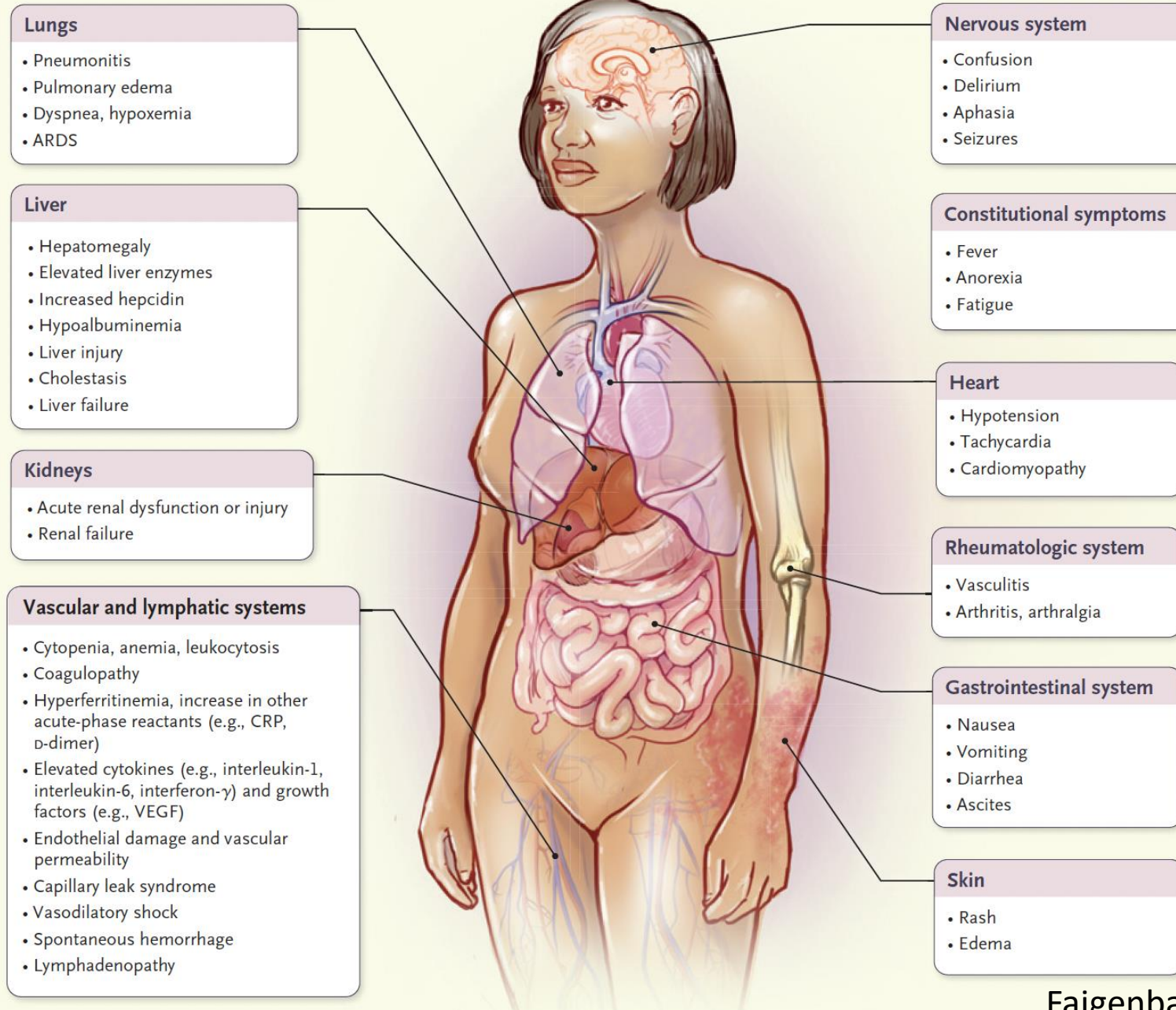

Fajgenbaum, et al. NEJM 2020



Exotic Viral Hepatitis: Pathogenesis in Liver

van Leeuwen LPM, et al. J Hepatol. 2022

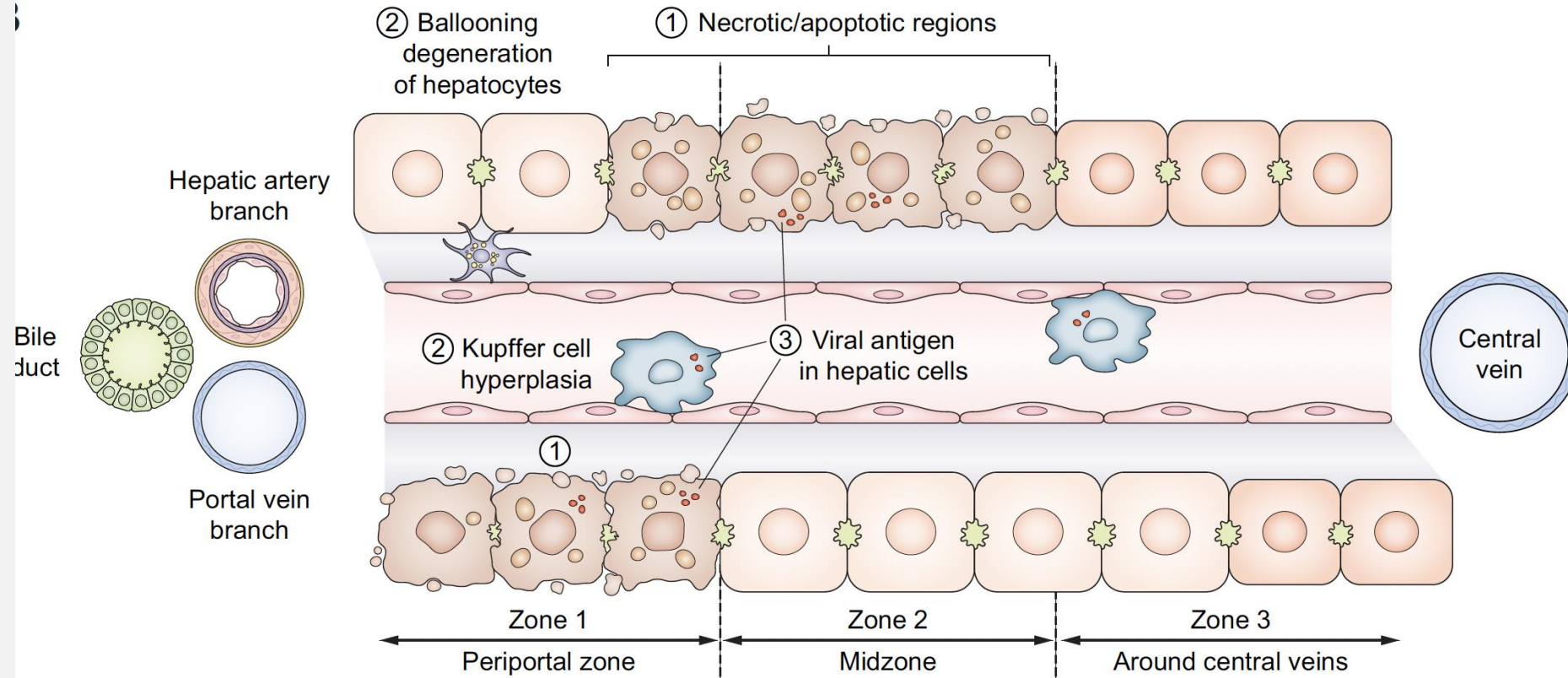
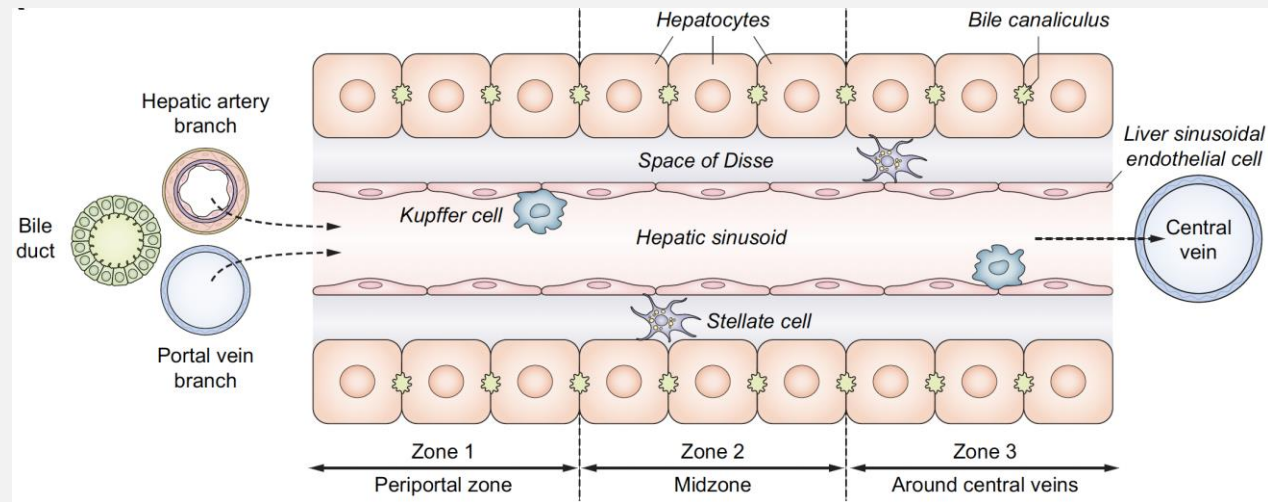



Clinical Sequela of Ebola Virus Disease Survivors

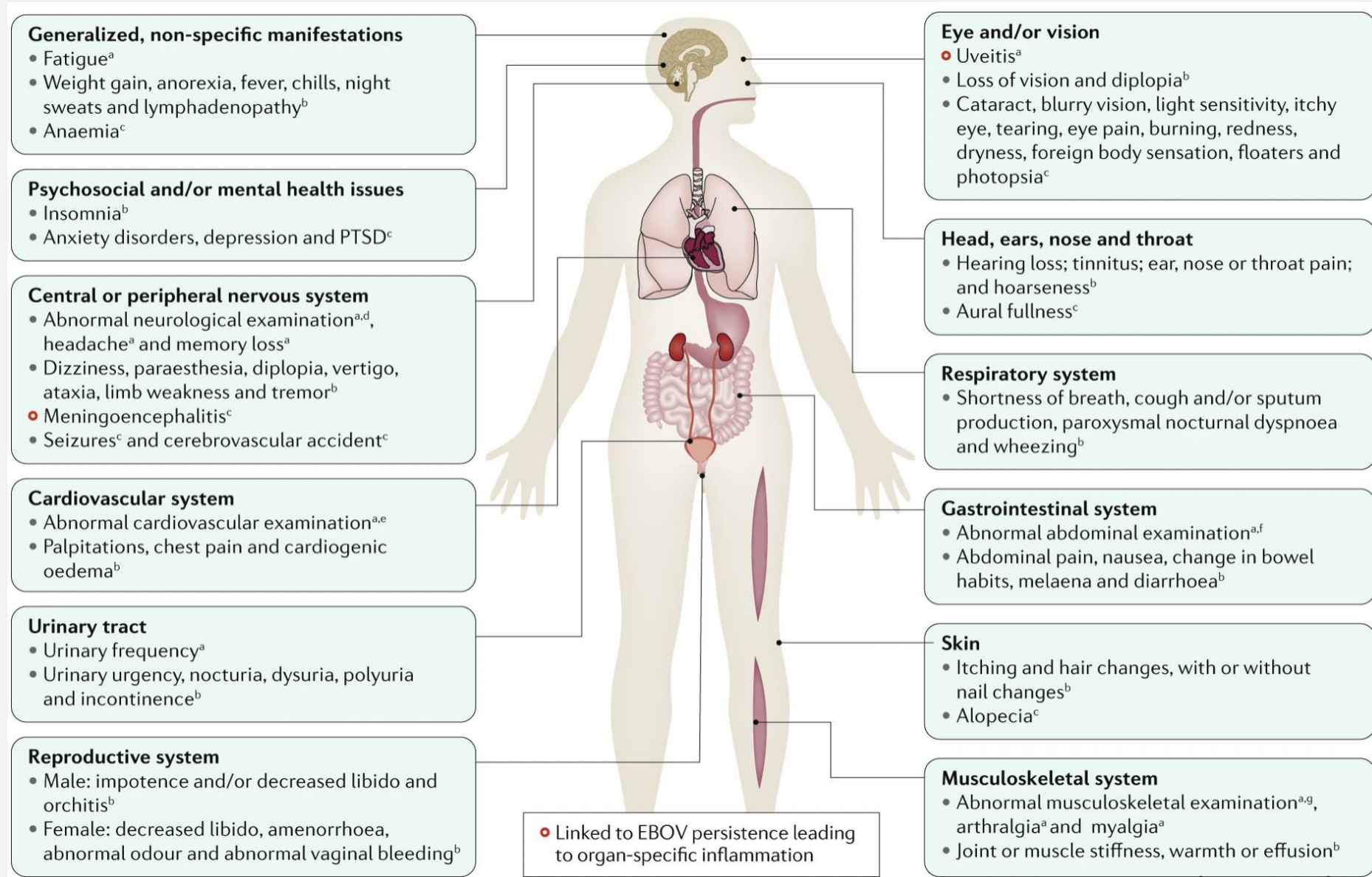

Fatality Among Hospitalized Children

33 children in Iran: 24% (Sharifi-Mood, et al. Ped Infect Dis J 2008)

31 children in Turkey: 0% (Tezer H, et al. J Clin Virol 2010)

50 children in Turkey; 0% (Tuygun N, et al. Pediatr Int 2011)

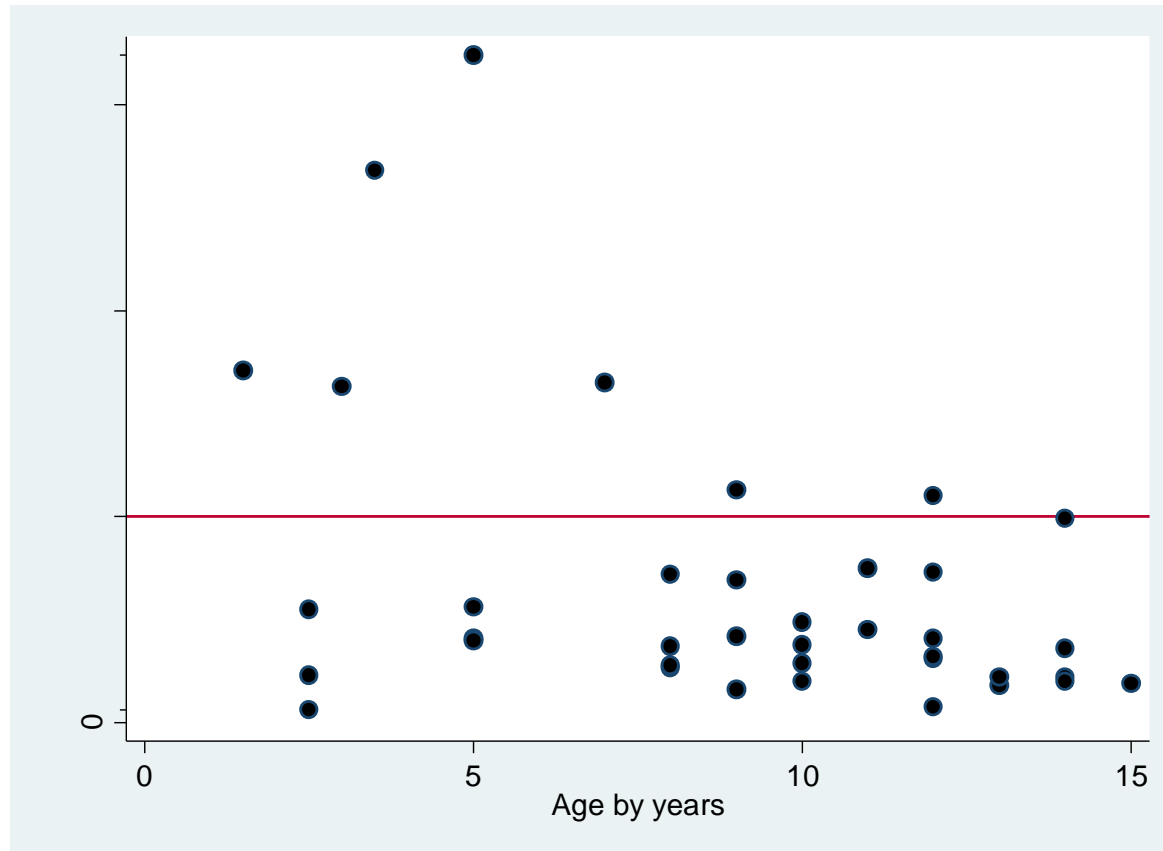



Crimean-Congo Hemorrhagic Fever: Reinfection, Humoral and Cellular Immune Responses

Pınarlık et al. | The Journal of Infectious Diseases

Study Population: Adult survivors with PCR-proven CCHF history admitted to the two hospitals in an epidemic center

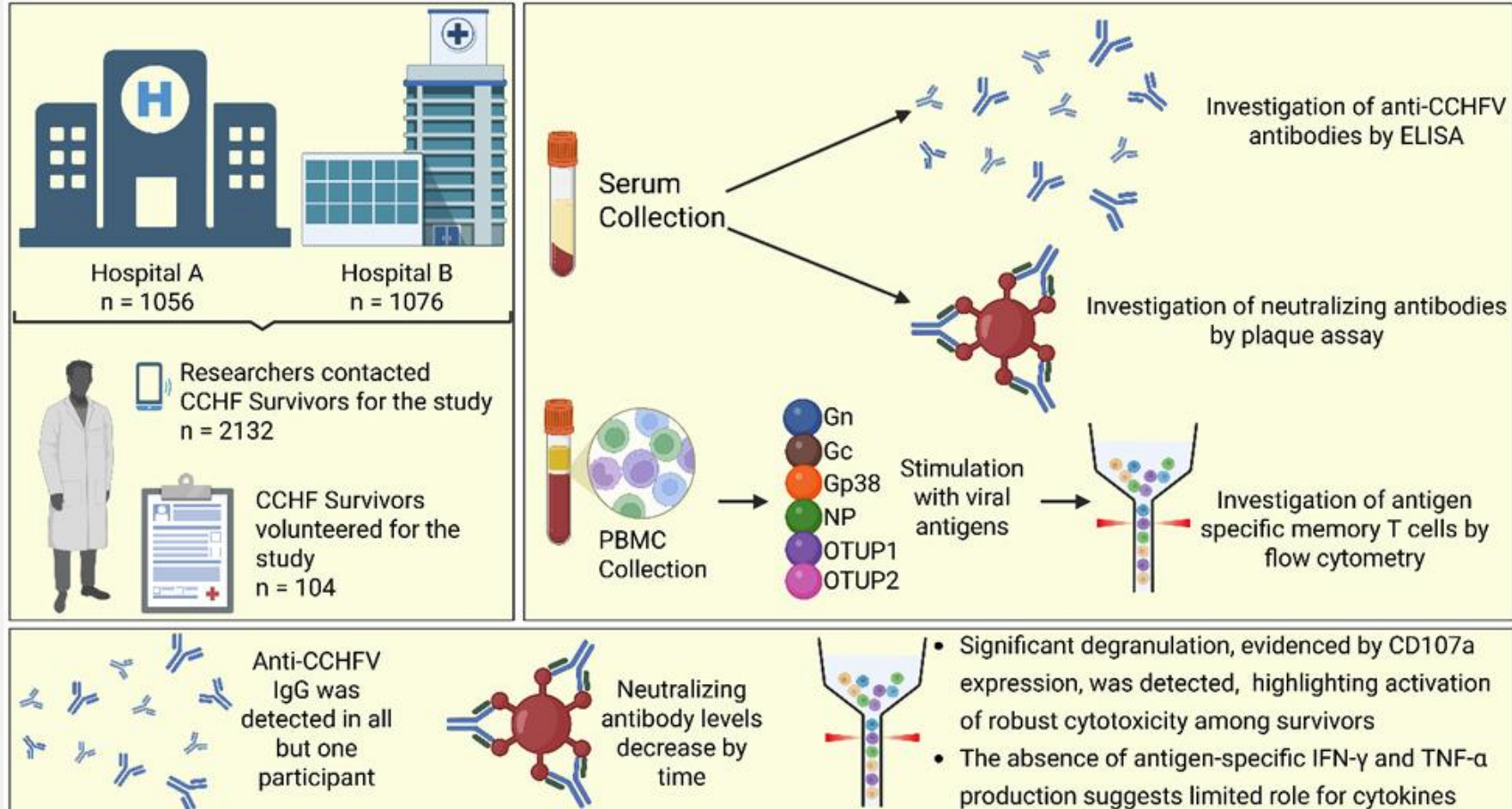

Conclusion: Humoral and cellular immune memory can be detected up to 13 years after Crimean-Congo hemorrhagic fever infection. Immune protection fades and reinfection is possible in rare cases.



Neutralizing Antibody Levels among CCHF Survivors

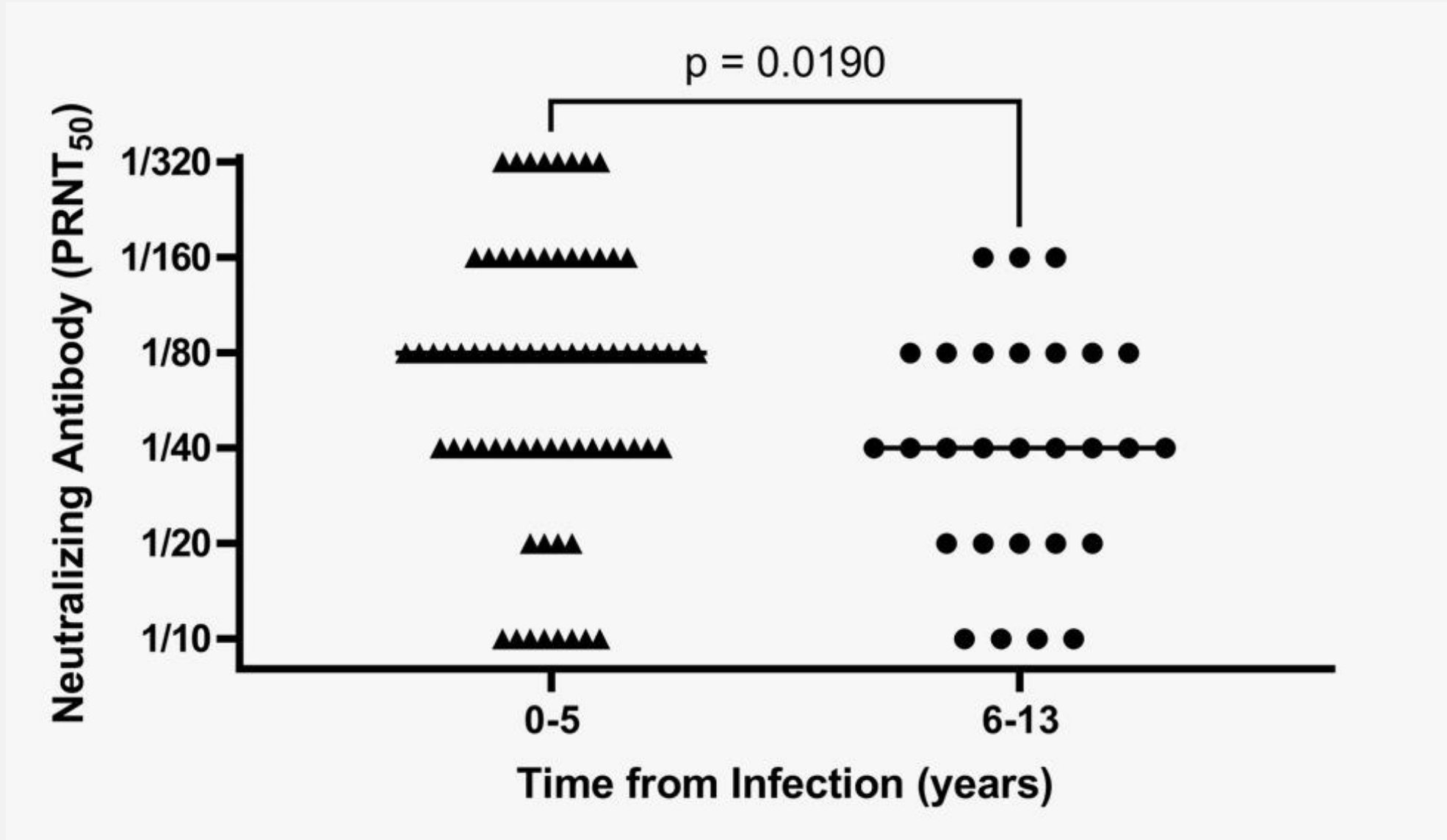

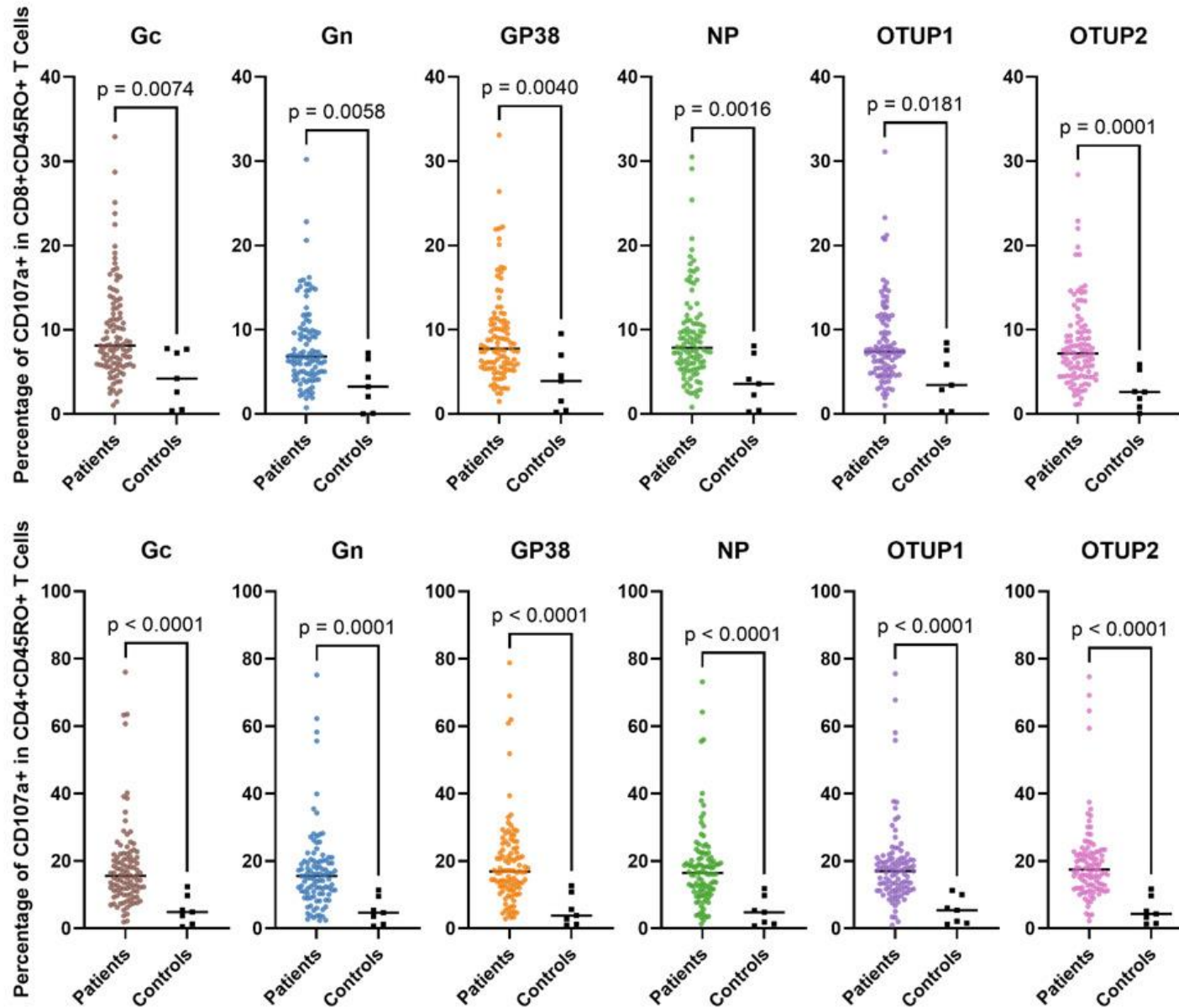



CCHF Survivors Project

- Current information: CCHFV infection provides lifelong immunity
- We detected a case reinfected with CCHF virus 11 years after first infection

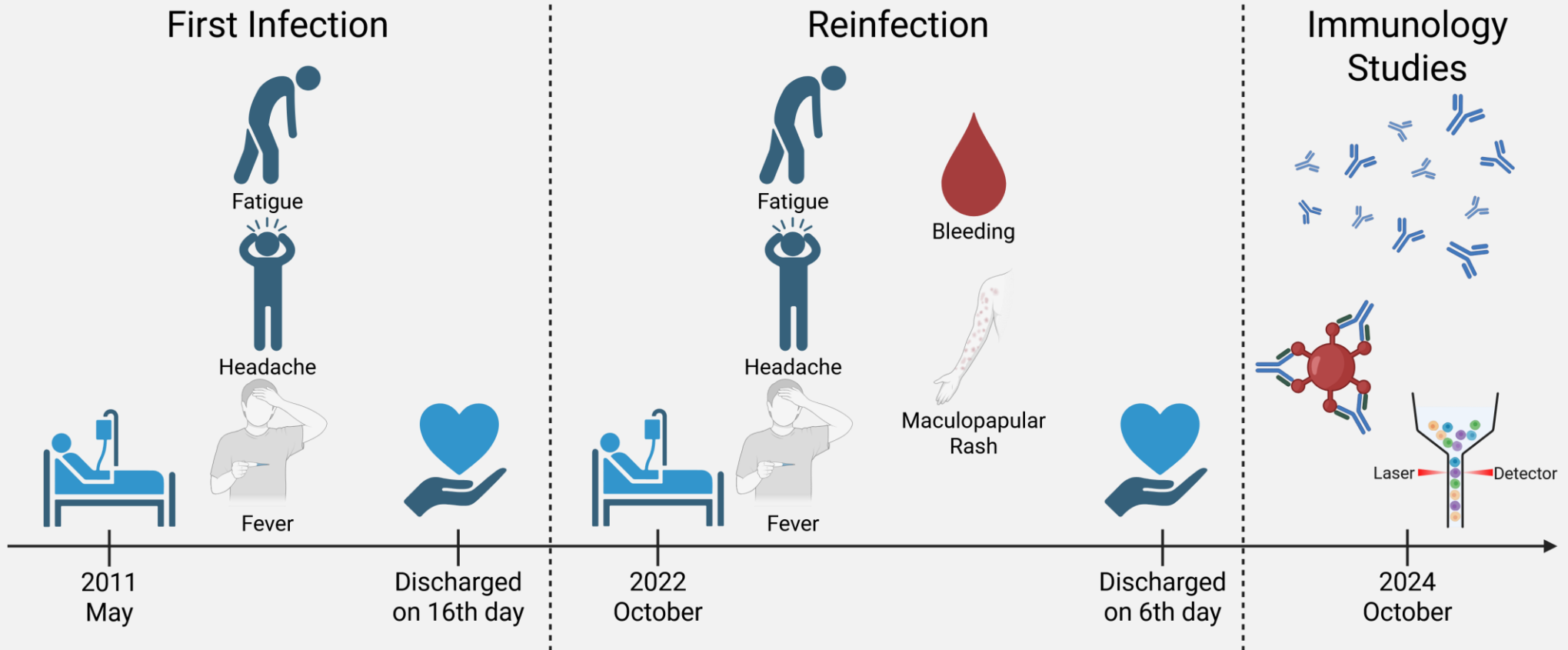



CCHF Research Milestones (1944-2024)

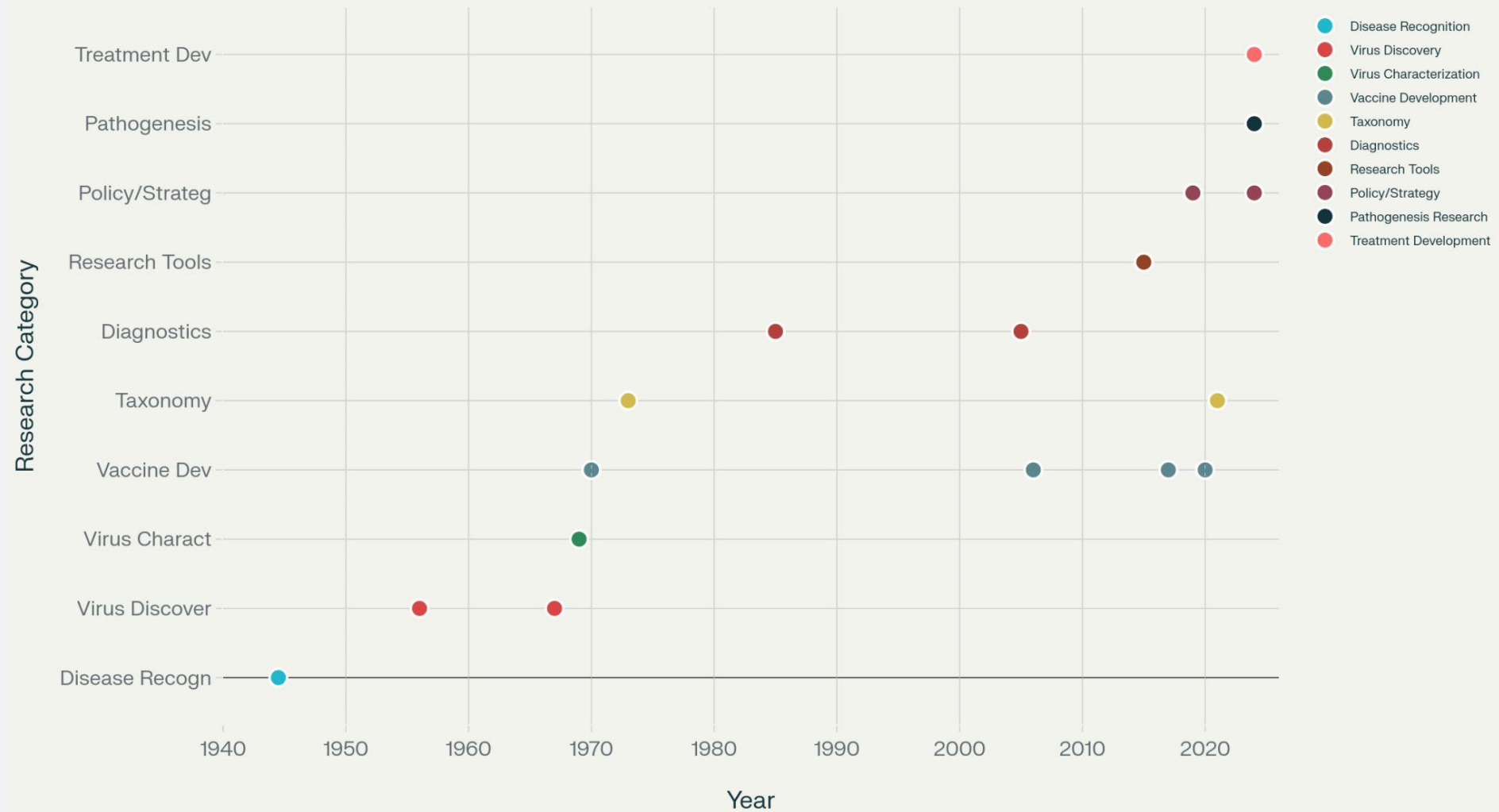

By Dennis Bente



Thank you



ESCMID
COLLABORATIVE CENTRE

<https://kuiscid.ku.edu.tr>